

CAMLOG® SCREW-LINE IMPLANT BASIC INFORMATION SURGICAL PROCEDURE

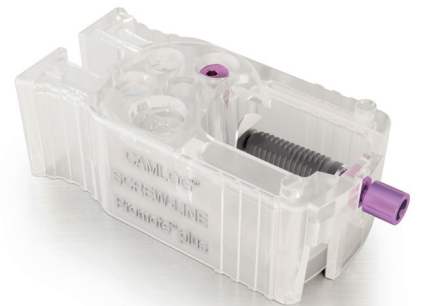

CAMLOG® SCREW-LINE implants
CAMLOG® Implant position planning
Surgical procedure
Healing options



TABLE OF CONTENTS

GENERAL SYSTEM INFORMATION ABOUT THE CAMLOG® IMPLANT SYSTEM	2
CAMLOG® SCREW-LINE IMPLANTS	3
GENERAL	3
IMPLANT DIMENSIONS	5
OPTION PLATFORM SWITCHING	6
IMPLANT POSITION PLANNING	7
LEVERAGE RATIO ON IMPLANT	7
RESTORATIONS	7
X-RAY/DRILLING TEMPLATE WITH SLEEVE FOR CT PLANNING	10
ORTHOPANTOMOGRAPH	10
FABRICATING THE DRILLING TEMPLATE WITH SLEEVE FOR CT PLANNING	11
SURGERY-SET FOR CAMLOG® SCREW-LINE IMPLANTS	12
SURGICAL PROCEDURE	14
DRILLING SEQUENCES FOR IMPLANT BED PREPARATION	14
INCISION LINE	17
IMPLANT BED PREPARATION	18
IMPLANTATION	26
ADDITIONAL INSTRUMENTS	35
SUBMERGED HEALING	36
TRANSGINGIVAL HEALING	38
FURTHER INFORMATION	44

GENERAL SYSTEM INFORMATION ABOUT THE CAMLOG® IMPLANT SYSTEM

The CAMLOG® Implant System is based on years of clinical and laboratory experience and is a user-friendly, consequently prosthetically oriented implant system.

All CAMLOG® Products are manufactured with the latest state-of-the-art technology. They are continuously developed by the company's research and development team in collaboration with clinics, universities and dental technicians and therefore stays abreast of the latest technology.

The CAMLOG® and CONELOG® Implant Systems are well documented scientifically. Studies* support this with respect to many parameters including the implant surface, time of implantation and/or implant loading, primary stability, connection design or type of superstructure. The long-term results of the CAMLOG® Implant System are convincing.

IMPORTANT NOTE

The descriptions that follow are not adequate to permit immediate use of the CAMLOG®/CONELOG® Implant System. Instruction by a surgeon experienced in using the CAMLOG®/CONELOG® Implant System is strongly recommended. CAMLOG®/CONELOG® dental implants and abutments should only be used by dentists, physicians, surgeons and dental technicians who have been trained in using the system. CAMLOG regularly offers relevant courses and training sessions.

Methodical errors made during the treatment can result in loss of the implant and significant loss of the peri-implant bone.

COLOR CODING

COLOR CODING OF THE SURGICAL AND PROSTHETIC CAMLOG® PRODUCTS

	COLOR	DIAMETER
	Gray	3.3 mm
	Yellow	3.8 mm
	Red	4.3 mm
	Blue	5.0 mm
	Green	6.0 mm

* see advanced documentation on page 44

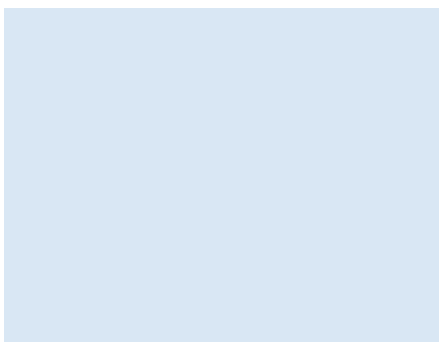

CAMLOG® SCREW-LINE IMPLANT

GENERAL

CAMLOG® SCREW-LINE implants are endosseous implants available in various lengths and diameters. They are surgically inserted in the bone of the maxilla and/or mandible and serve as an anchor for functional and esthetic oral restorations for partially and fully edentulous patients. The prosthetic restoration is performed with single crowns, bridges or full dentures that are attached to the CAMLOG® Implants with the appropriate CAMLOG® Components. CAMLOG® SCREW-LINE implants are distinguished by:

- A slight tapered external geometry,
- A machined implant neck portion available in two height: 1.4 mm at CAMLOG® SCREW-LINE Promote® Implant and 0.4 mm at CAMLOG® SCREW-LINE Promote® plus Implant,
- Option Platform Switching,
- Promote® Surface,
- Tube-in-Tube connection with three symmetrically arranged grooves and
- efficient implant handling with mounted insertion post.

The CAMLOG® SCREW-LINE implant is not only suitable for late implantations but also for immediate or delayed immediate implantations in maxillary or mandibular bone. The selected healing technique can be either submerged or transgingival. In the case of a one-stage surgical procedure, the implants can be loaded immediately if good primary stability has been achieved and functional loading is appropriate.

The implant is easily inserted because the taper of the implant body (3°–9° depending on length and diameter) induce self centering. The self-cutting thread provides for continuous grip on the bone and high primary stability.

RANGE OF USE FOR CAMLOG® SCREW LINE IMPLANT

A deeper coronal implant shoulder is especially beneficial in treating esthetically challenging areas. The machined segment of a CAMLOG® SCREW-LINE Implant Promote® plus surface measures only 0.4 mm. The implant can therefore be inserted into the bone as far as this segment*. The following clinical prerequisites should be present:

- Normal to thick biotype
- Gingival height of at least 3.0 mm
- Minimum width of 1.0 mm of the attached gingiva
- Minimum distance of 2.0 mm between attached gingiva and mimetic musculature.

* Schwarz F, Alcoforado G, Nelson K, Schaer A, Taylor T, Beuer F, Strietzel FP. Impact of implant–abutment connection, positioning of the machined collar/microgap, and platform switching on crestal bone level changes. Camlog Foundation Consensus Report. Clin.Oral Impl. Res. 2014;25(11):1301-1303

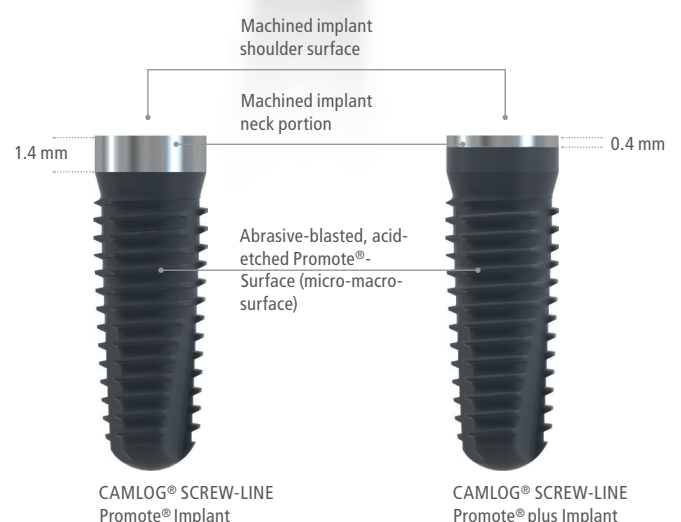
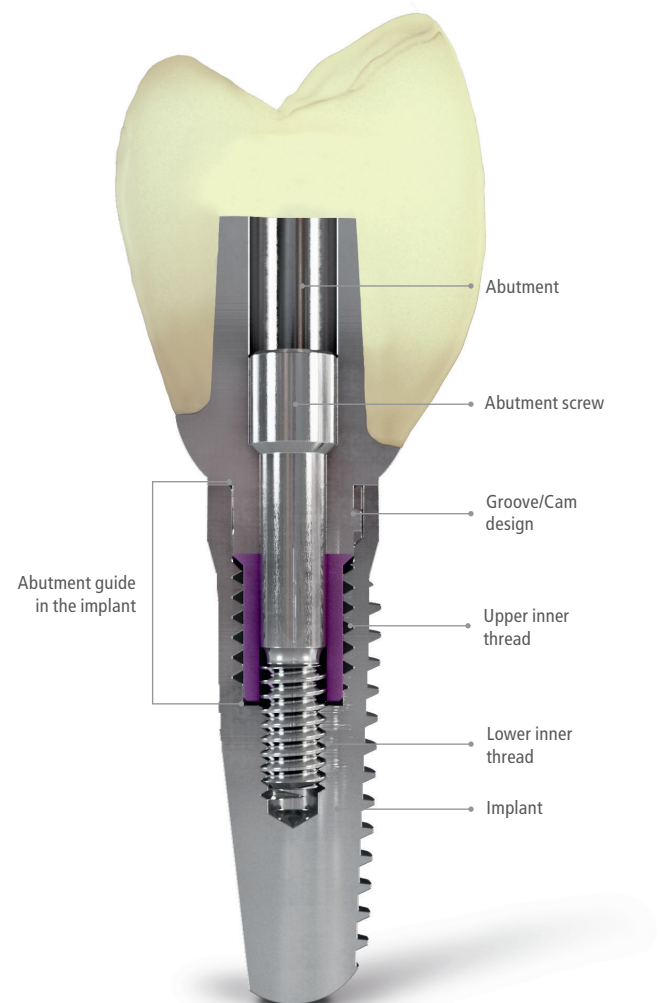

CAMLOG® SCREW-LINE IMPLANT

MATERIALS

All CAMLOG® SCREW-LINE implants are made of titanium grade 4. The CAMLOG® Abutments and abutment screws are made of titanium alloy Ti6Al4V ELI.

PRODUCT PRECISION

For the most part, the inner and outer geometry of the CAMLOG® Implants and abutments are rotary machined. As a result, the tolerances can be kept very small as well as excellent component precision without impacting the material structure. The CAMLOG® Implant abutment connection ensures a very precise, stable and rotation-resistant connection to the CAMLOG® Prosthetic components.



INNER CONFIGURATION OF THE IMPLANT

The CAMLOG® Tube-in-Tube® Connection is a 5.4 mm deep implant-abutment connection with antirotational locking mechanism. The three symmetrically arranged grooves are located in the 1.9 mm deep cylindrical drill hole in the coronal region. This region leads apically to an upper thread. This is followed by a thinner and longish cylindrical threaded bore. The abutment screw of the two-piece abutment engages in this lower inner thread. The CAMLOG® Tube-in-Tube® Connection had undergone extensive scientific studies and achieved above average good results for tightness and precision fit.

Implants with Ø 3.3 mm dispose only the Lower inner thread.

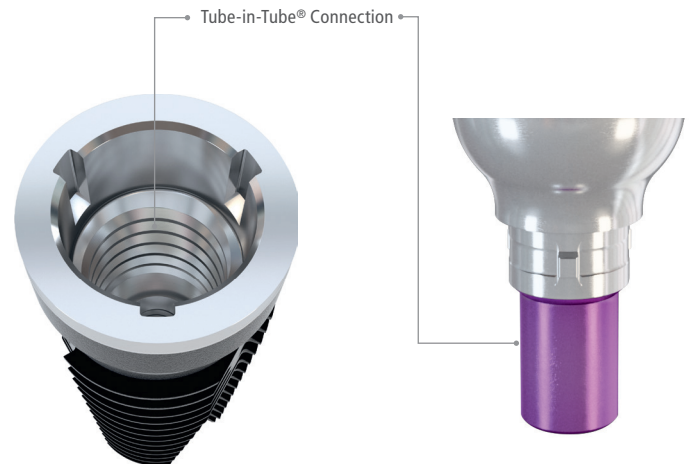

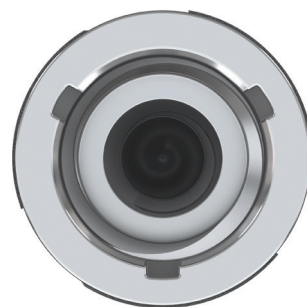

For optimal positioning of the abutments in the implant, they should be aligned in the bone so that one of the three grooves points vestibularly. The drivers and insertion post include markings on the outside that correspond to the three grooves of the implant inner configuration.



Groove/cam design of CAMLOG®
Implant abutment connection

IMPLANT DIMENSIONS

	Article	Art.-No.	Ø	L	A Ø
	CAMLOG® SCREW-LINE Implant, Promote® incl. insertion post and cover screw, sterile Material Titanium Grade 4	K1044.3311*	3.3 mm	11 mm	2.7 mm
		K1044.3313*		13 mm	
		K1044.3316*		16 mm	
		K1044.3809	3.8 mm	9 mm	3.5 mm
		K1044.3811		11 mm	
		K1044.3813		13 mm	
		K1044.3816	4.3 mm	16 mm	3.9 mm
		K1044.4309		9 mm	
		K1044.4311		11 mm	
		K1044.4313	5.0 mm	13 mm	4.6 mm
		K1044.4316		16 mm	
		K1044.5009		9 mm	
		K1044.5011	6.0 mm	11 mm	5.5 mm
		K1044.5013		13 mm	
		K1044.5016		16 mm	
		K1044.6009	6.0 mm	9 mm	5.5 mm
		K1044.6011		11 mm	
		K1044.6013		13 mm	
K1044.6016	16 mm				
	CAMLOG® SCREW-LINE Implant, Promote® plus incl. insertion post and cover screw, sterile Material Titanium Grade 4	K1054.3311*	3.3 mm	11 mm	2.7 mm
		K1054.3313*		13 mm	
		K1054.3316*		16 mm	
		K1054.3809	3.8 mm	9 mm	3.5 mm
		K1054.3811		11 mm	
		K1054.3813		13 mm	
		K1054.3816	4.3 mm	16 mm	3.9 mm
		K1054.4309		9 mm	
		K1054.4311		11 mm	
		K1054.4313	5.0 mm	13 mm	4.6 mm
		K1054.4316		16 mm	
		K1054.5009		9 mm	
		K1054.5011	6.0 mm	11 mm	5.5 mm
		K1054.5013		13 mm	
		K1054.5016		16 mm	
		K1054.6009	6.0 mm	9 mm	5.5 mm
		K1054.6011		11 mm	
		K1054.6013		13 mm	
K1054.6016	16 mm				

Note: The implant length (L) is the distance from the apical curve to the machined shoulder surface of the implant.

A Ø: Apical diameter (mean value)

* IMPORTANT NOTE

CAMLOG® Implants with a diameter of Ø 3.3 mm. These are an alternative in cases where the alveolar ridge width is only 5–6 mm. Because of their lower mechanical strength compared with larger diameter implants, they should only be used under the following conditions:

- As single implants, they should be used only to replace mandibular incisors and/or maxillary lateral incisors.
- Edentulous mandibles can be prosthetically restored with a barsplinted restoration consisting of at least four implants Ø 3.3 mm without distal extensions.

- Implants of Ø 3.3 mm are suitable for a partially edentulous arch when combined with implants of larger diameter for splinted superstructures. However, the limited strength of the implants with Ø 3.3 mm must be taken into account.
- Avoid excessive mechanical stressing of the implants when using ball abutments in combination with Ø 3.3 mm implants.
- The healing time for Ø 3.3 mm implants is at least 12 weeks.
- Double crown constructions are not allowed on Ø 3.3 mm implants.

CAMLOG® SCREW-LINE IMPLANT

OPTION PLATFORM SWITCHING

CAMLOG® SCREW-LINE implants allow the option Platform Switching (PS).

The platform switching option must only be used with the CAMLOG® SCREW-LINE implants with K article numbers and prosthetics components PS with K article numbers. Appropriate healing caps, impression posts and abutments are available and are marked with PS:

CAMLOG® HEALING CAPS PS

CAMLOG® Healing caps PS (cylindrical, wide body, bottleneck) are tapered in diameter in the area of the implant shoulder and thus enable the soft tissue to adapt over the implant shoulder.

IMPORTANT NOTE

If CAMLOG® Healing caps PS are used for healing, the later prosthetic restoration, incl. the impression, must use CAMLOG® Prosthetics components PS for platform switching to prevent tissue injury.

CAMLOG® IMPRESSION POSTS PS

Use of the CAMLOG® Healing caps PS requires application of the geometrically adapted CAMLOG® Impression posts PS for platform switching due to soft tissue adaptation over the implant shoulder.

CAMLOG® ABUTMENTS PS

CAMLOG® Abutments PS are also tapered in the area of the shoulder support making it possible to adapt soft tissue over the implant shoulder for the prosthetic restoration.



cylindrical

wide body

bottleneck

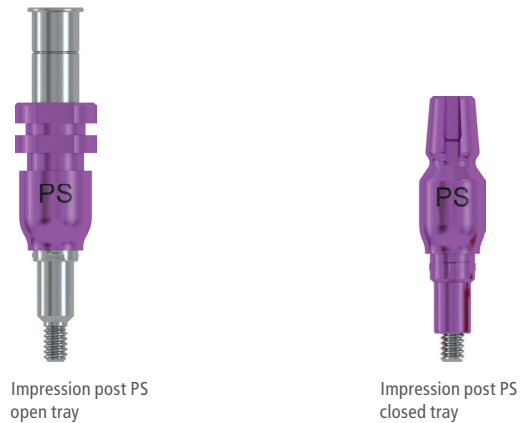

Impression post PS open tray

Impression post PS closed tray

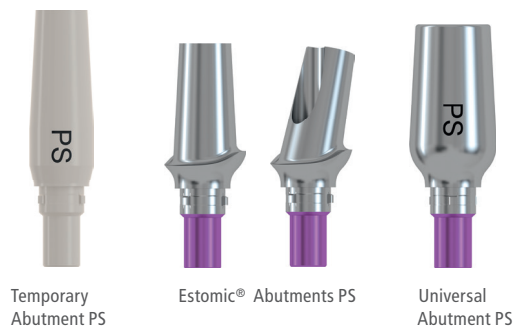

Temporary Abutment PS

Estomic® Abutments PS

Universal Abutment PS

IMPLANT POSITION PLANNING

The planning of implant-prosthetic reconstruction requires a team approach and a high level of attention to detail and clinical experience of all concerned. This is equally true for the restorative dentist, the surgeon, the dental technician, and the dental office support staff such as the nurse, hygienist and chair side assistant.

The following aspects should be taken into account during planning:

LEVERAGE RATION ON IMPLANT

The loading of the implant-bone interface is determined by the leverage ratio from the osseointegration-related resistance to the prosthetic load arm (equal to the supracrestal implant length plus crown length from the implant shoulder). If the implant length (IL) is less than the length of the crown (CL), measures must be taken to reduce loading (e.g. using prosthetic splints).

The ratio of crown length (CL) to implant length (IL) should be 0.8:1 maximum.

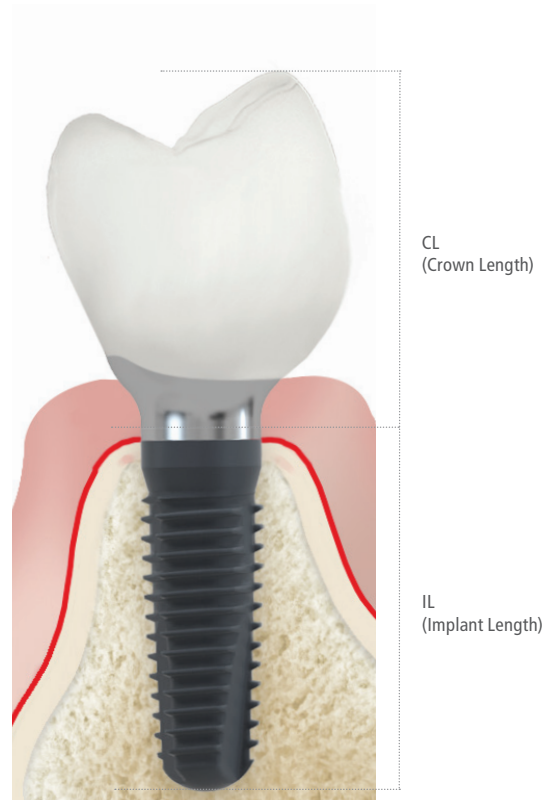

RESTORATIONS

FIXED RESTORATION

Single Crowns

Single-crown treatment is a possible form of treatment under the aspect of a "Restitutio ad integrum". It contains all the beneficial elements of periodontal prosthetic rehabilitation:

- Physiologically adequate biomechanical loading prevents further atrophy of the hard- and soft tissue
- Good preconditions for natural-looking esthetics are established
- Oral hygiene is simple
- Fabrication is technically straightforward
- Readily extendable/alterable.

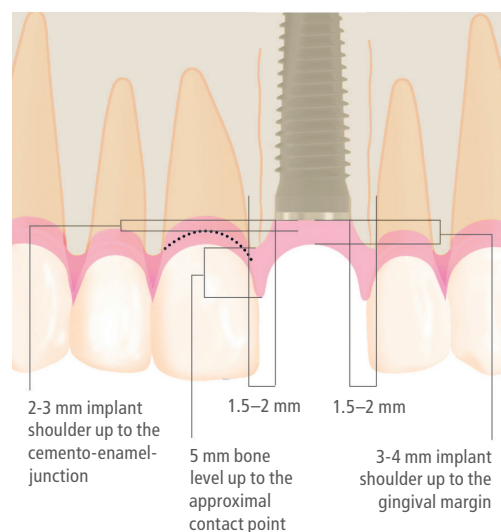

IMPLANT POSITION PLANNING

Esthetically challenging region

To achieve an esthetically successful estoration, a number of important elements are required: a harmonious gingiva line, optimal implant positioning as well as vertical/orofacial and mesio-distal dimensions, a physiological crown shape, and the presence of interdental papillae. The indications for the hard-tissue configurations to be preserved and for soft-tissue management must be observed during planning.

Implant diameters and lengths must be sized properly to leave adequate bone (at least 1 mm) around the implant. Maintain a minimum distance of 1.5 mm to an adjacent natural tooth and 3 mm to an adjacent implant.

Structure-preserving or structure-sparing procedures must be used during flap creation and implant placement. In addition, oral hygiene requirements must be kept in mind during planning.

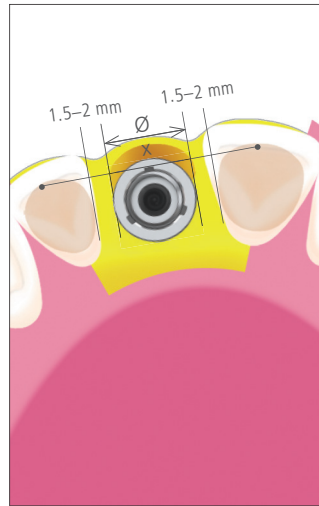

Mesio-distal implant position at bone level

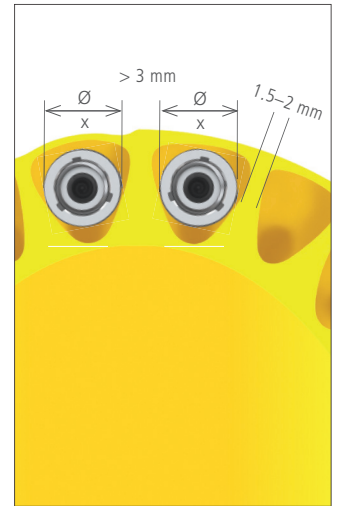

Distances at bone level

Splinted crowns

In the event of unfavorable leverage relations around the implant, a choice must be made between a longer implant or, if this is anatomically impossible, splinting adjacent crowns. If splinting is required by reason of stability, then hygienic requirements must also be taken into account.

Development of a uniform insertion direction for the crown block must be part of the abutment preparation. The implant-to-abutment connection should not be altered.

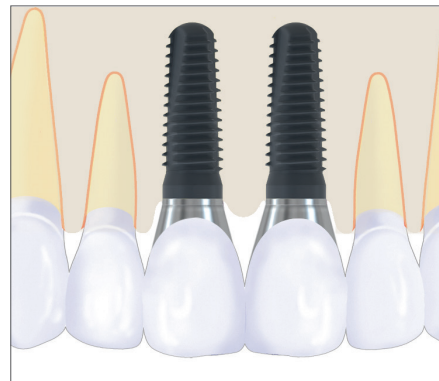

Single-crown restoration



Crown-splinting



Implant-supported bridges

CAMLOG® SCREW-LINE implants are as well dedicated for Implant-supported bridges. Implant distribution should be structured in such a way that spanned segments are kept small.

Development of a uniform insertion direction for the crown block should be part of the abutment preparation. The implant-to-abutment connection should not be altered.



Cement-retained bridge

REMOVABLE RESTORATIONS

A hybrid denture may be implant-retained and mucosa-supported, or simply implant-supported. The tension-free seat of a secondary (telescopic crown) or primary (bar-) splinted structure on implants is called "passive fit".

In the case of telescopic crowns, this is obtained through intraoral bonding of the secondary crowns (preferably galvano crowns) onto the tertiary framework. In the case of bar structures, it involves the use of bar sleeves for a "passive fit" and intraoral bonding of the titanium bonding base. The idea is to create a fit that is free from stress or to minimize stress on the implants.

When planning a removable denture, the implants should be placed so that, if necessary, extending to a fixed restoration is possible.



Tension-free seat through intraoral bonding of the secondary crowns onto the tertiary framework

Double crowns

The production precision of the CAMLOG® Connection is particularly necessary with a telescopic crown restoration since the abutments can be fastened always in the same, exactly defined position on the implant. A precision fit for the removable superstructure is made simple and consistent in every case.

FABRICATING THE DRILLING TEMPLATE WITH CT-TUBES FOR CT-PLANNING

If a planning or x-ray template with tubes for CT-planning was created, it can be converted into a drilling template after adjusting the tube positions based on the implant planning. If required, the template is reduced to an outline after preparation of the flap to ensure it stays in position during surgery (dental or gingival base outside the surgical area).

PILOT DRILLING WITH CT-TUBES FOR CT-PLANNING

The pilot drill without coil has a 2.0 mm diameter. It can also be used with the CT-tube for drill Ø 2.0 mm which has a 2.1 mm inner diameter. There are ring markings, whose lower edges define the drill depth of 7*, 9, 11, 13, 16, 18 and 20 mm. The thickness of each ring mark is 0.4 mm. The 18 and 20 mm markings are not filled in and are used for orientation when using the 4 mm long CT-tube with 2.1 mm internal diameter.

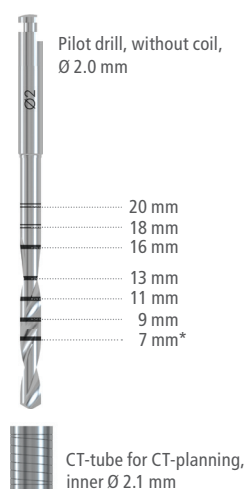

IMPORTANT NOTE

Only use CT-tubes for drill Ø 2.0 mm with 2.1 mm internal diameter in conjunction with the pilot drill.

* The lowest marking corresponds to a drilling depth of 7 mm and is of no significance for the CAMLOG® SCREW-LINE implants.

SURGERY-SET FOR CAMLOG® SCREW-LINE IMPLANTS

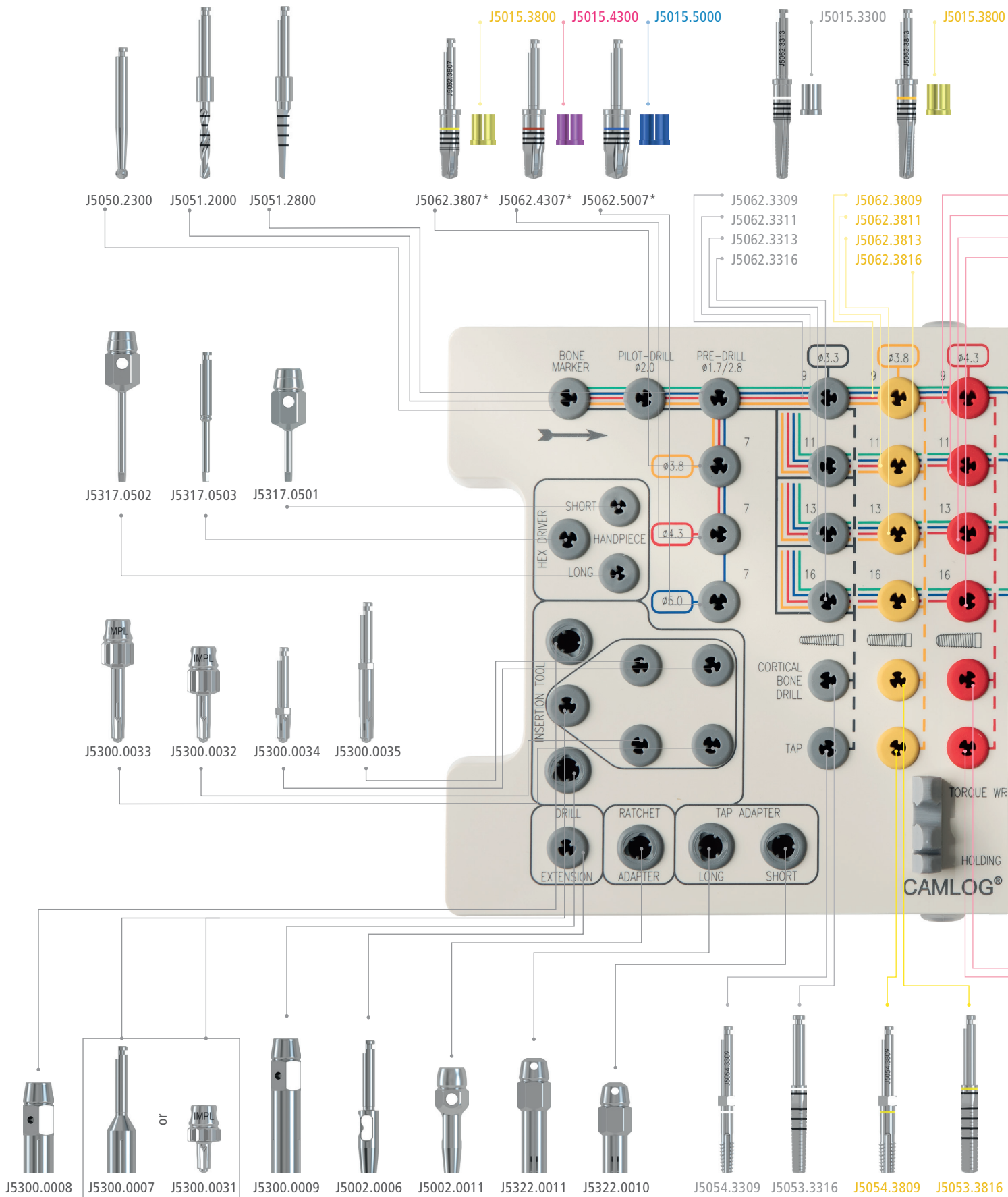

* only for CONELOG® SCREW-LINE implants with length of 7 mm
 ** have to be ordered separately

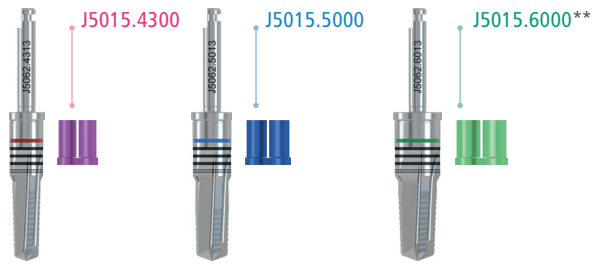

The same surgery set is used for the CONELOG® SCREW-LINE implants as for the CAMLOG® SCREW-LINE implants.

The drills are arranged and sorted in the set according to the treatment sequence. Color lines indicate the exact drilling sequence.

- J5062.4309
- J5062.4311
- J5062.4313
- J5062.4316
- J5062.5009
- J5062.5011
- J5062.5013
- J5062.5016
- J5062.6009**
- J5062.6011**
- J5062.6013**
- J5062.6016**

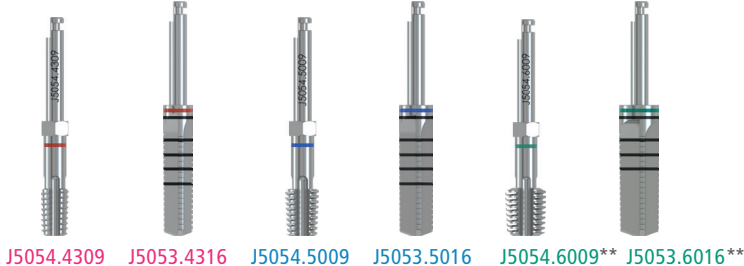
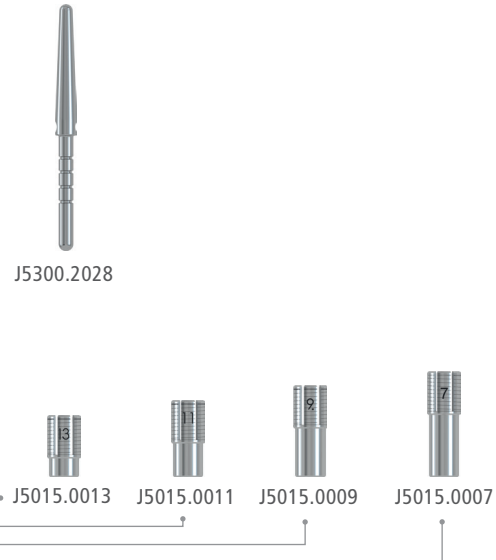
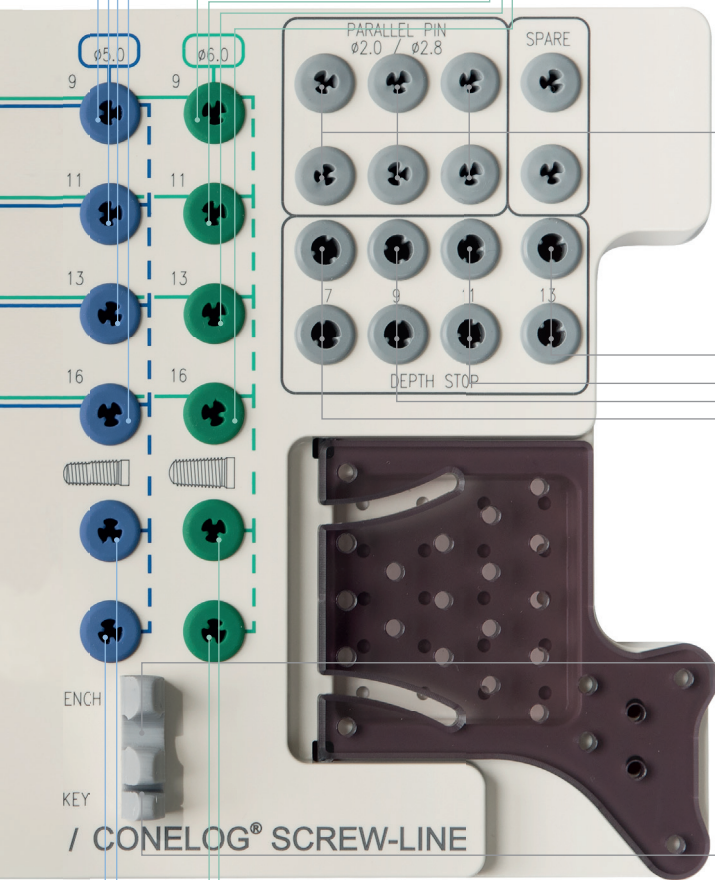

SURGICAL PROCEDURE

DRILLING SEQUENCES FOR IMPLANT BED PREPARATION

Overview of the implant bed preparation using the example of a CAMLOG® SCREW-LINE Promote® plus implant with a length of 13 mm.

- Punch-mark the desired implant position with the Ø 2.3 mm round bur
- Deep drill along the implant axial line with the Ø 2.0 mm pilot drill
- Depth control with the Ø 1.7–2.8/2.0 mm paralleling pin with depth marks
- Pre-drill with the Ø 1.7–2.8 mm pre-drill
- Check with the Ø 1.7–2.8/2.0 mm paralleling pin with depth marks
- Shape with the form drill
- Probe the implant bed hole for its bony end
- Cortical bone drilling ¹⁾
- Tap SCREW-LINE ²⁾

1) Form drills Cortical-Bone (CB) allow speed-reduced implant insertion in cortical bone for bone quality 1*.

2) We recommend using the tap for bone qualities 1* and 2*.

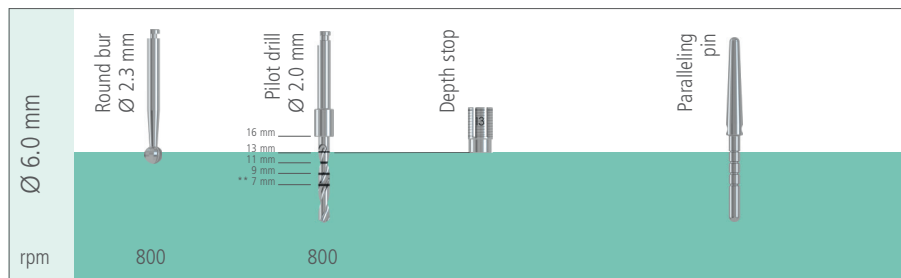
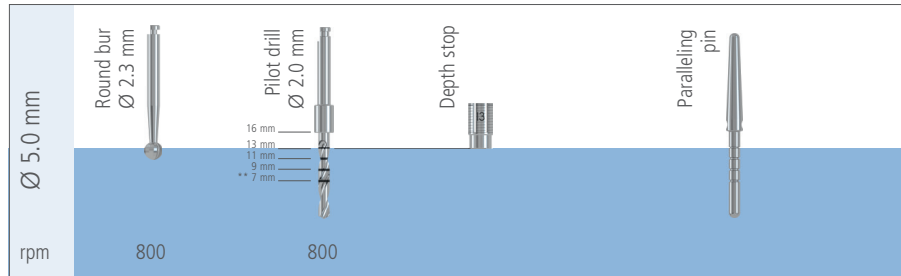
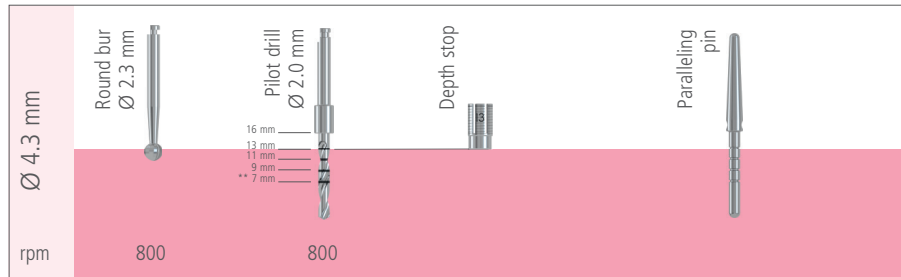
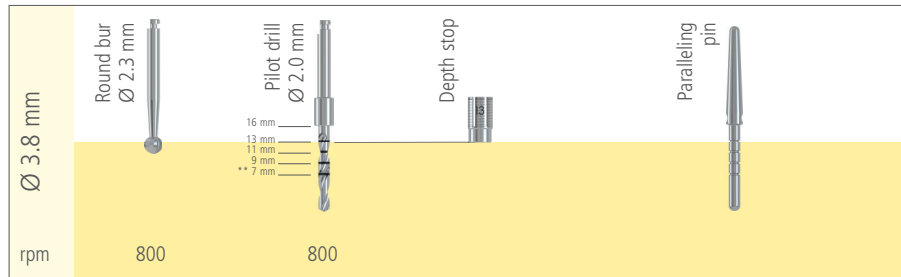
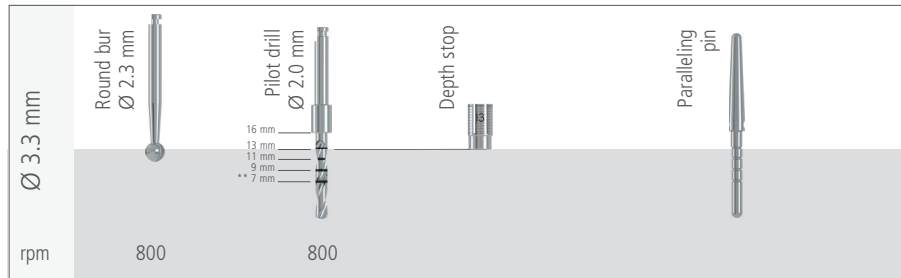

* Bone quality as documented in Lekholm U, Zarb GA. Patient selection and preparation. In: Branemark PI, Zarb GA, Albrektsson T, editors. Tissue-integrated prostheses-Osseointegration in Clinical Dentistry. Chicago: Quintessence Publishing Co; 1985. p. 199–209

** The lowest marking corresponds to a drilling depth of 7 mm and is of no significance for CAMLOG® SCREW-LINE implants.

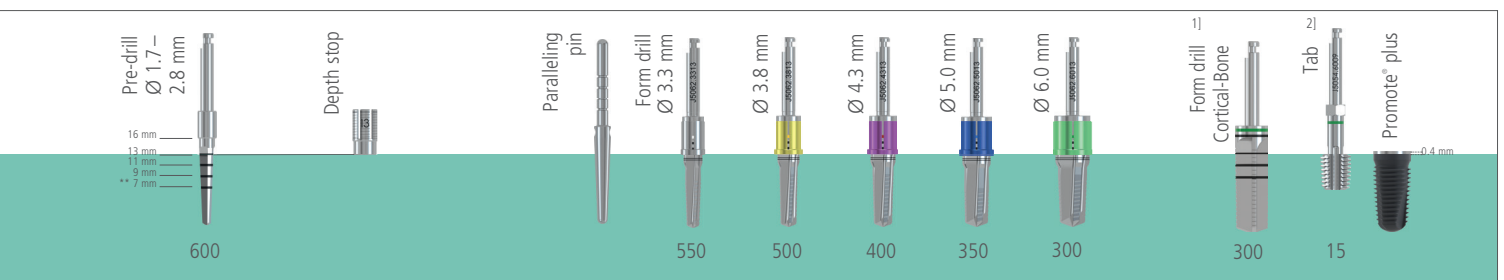
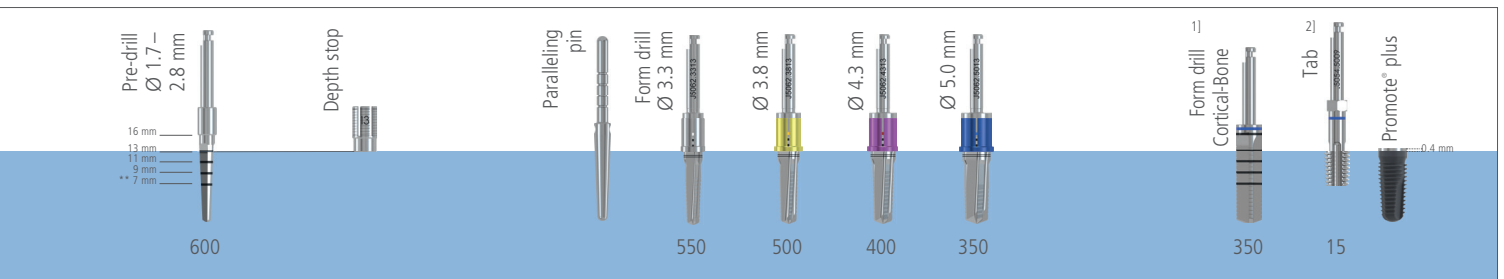
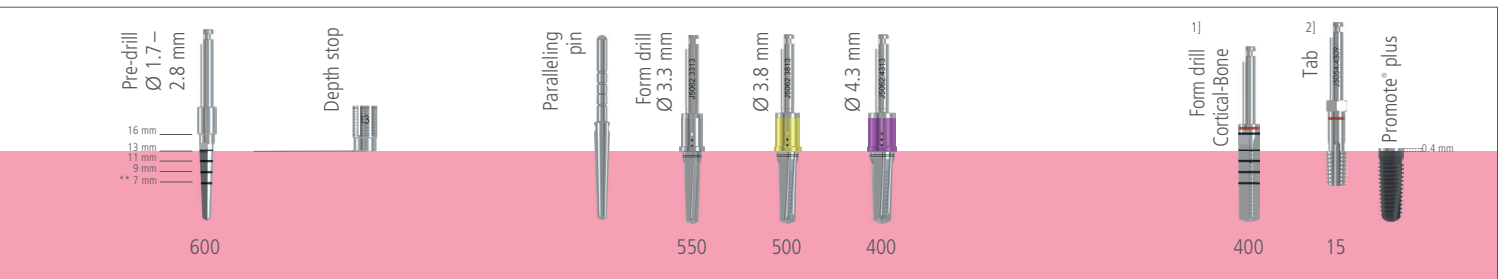
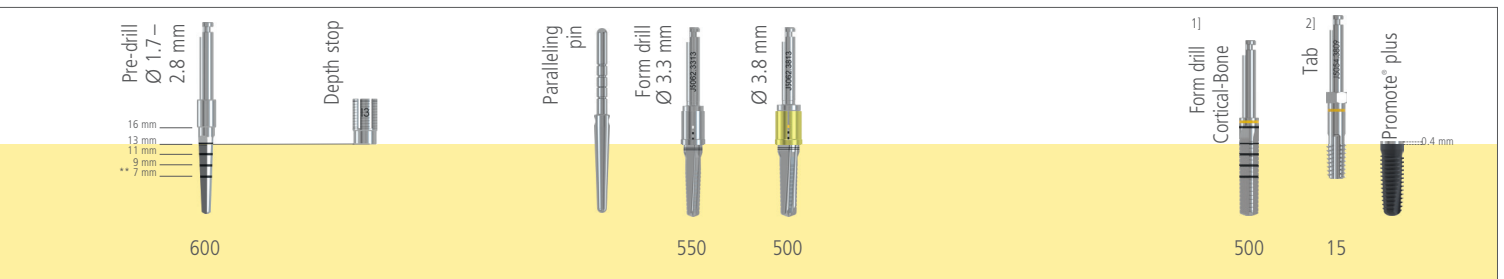
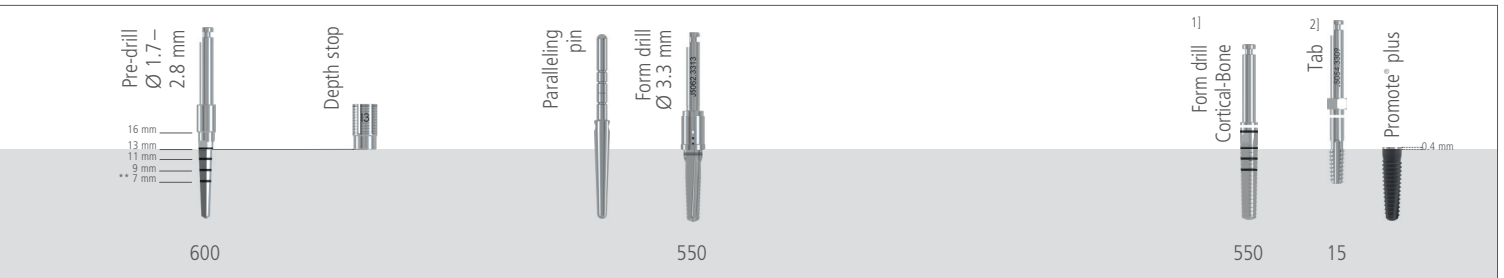

SURGICAL PROCEDURE

DRILL SPEEDS

The drill speed depends on the diameter. The recommended speeds are 300–800 rpm depending on the drill type (handpiece angle reduction ratio 16:1–20:1).

The recommended maximum drilling speed for thread tapping is 15 rpm (handpiece angle reduction ratio 70:1–100:1). The tap adapter for the torque wrench also allows manual tapping.

The lower edge of the depth mark is the reference for the preparation depth.

COOLING OF DRILLS

The cooling occur through external irrigation on the angled hand piece with sterile saline solution (pre-chilled to 5°C/41°F).

DRILL LIFE

Drill longevity depends on bone quality and drilling technique. The pilot drills, pre-drills, and form drills are good for 10–20 times. If excessive force has to be applied because of a dull drill, then change the drill immediately to prevent bone overheating.

Article	∅	drilling speed (rpm)
Round bur	–	800
Pilot drill with/without depth stop	2.0 mm	800
Pre-drill	1.7–2.8 mm	600
Form drill with/without depth stop	3.3 mm	550
	3.8 mm	500
	4.3 mm	400
	5.0 mm	350
	6.0 mm	300
Form drill cortical bone	3.3 mm	550
	3.8 mm	500
	4.3 mm	400
	5.0 mm	350
Tap	6.0 mm	300
	5.0 mm	max. 15
	4.3 mm	
	3.8 mm	
3.3 mm		

CAUTION

The maximum apical extension length of the drill is 0.4 mm.

INCISION LINE

The indication used as an example illustrates the insertion of a $\varnothing 4.3/13$ mm CAMLOG® SCREW-LINE Promote® plus implant in the lateral mandible. The implantation technique is two-step transperiosteal. A split flap preparation is selected for the incision line. We recommend this procedure in cases where there is sufficient bone width and no bone augmentation has to be performed. We recommend a split flap preparation only where the thickness of the mucosa is adequate. Otherwise a full mucoperiosteal flap preparation should be performed.

After performing a somewhat lingual, paracrestal mucosal incision, a predominantly epiperiosteal flap is created on the vestibular aspect. The muscle is divided and the preparation is continued for approximately another 5 mm. The mucosa is separated 2–3 mm lingually to simplify suturing later.

After marking the desired implant position (if necessary, with a drilling template), the periosteum is removed circularly only in the area around this site (with gingival punch or scalpel). Depending on the selected implant diameter and implant length, the implant bed is then shaped using the instruments designed for the CAMLOG® SCREW-LINE implant.

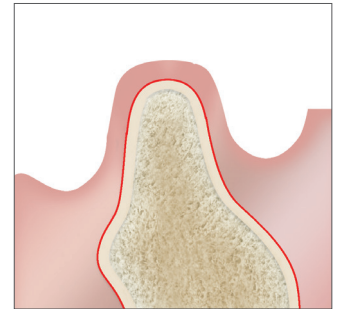

Initial situation

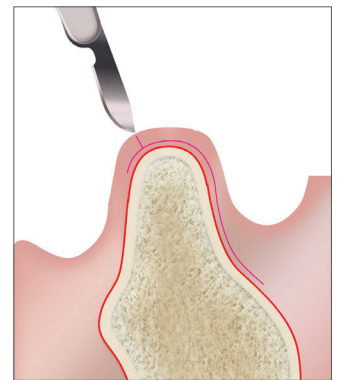

Mucosal incision

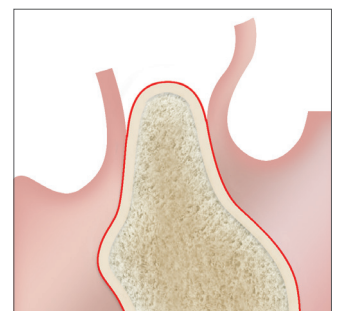

Epiperiosteal split-flap preparation

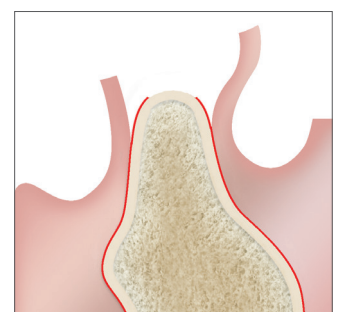

Removal of the periosteum at the implantation site

SURGICAL PROCEDURE

IMPLANT BED PREPARATION

GENERAL

DRILL EXTENSION

A drill extension is available to prevent resting of the angled handpiece on the remaining dentition during preparation of the implant bed adjacent to elongated teeth.

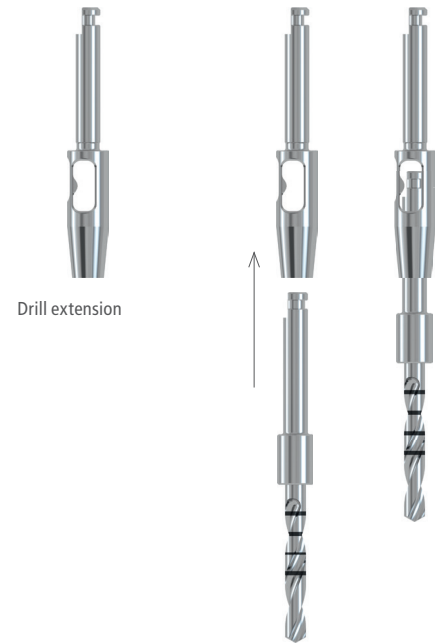

Drill extension

DEPTH STOP SCREW-LINE

The pilot drill SCREW-LINE and pre-drill have a maximum working length of 16 mm. The drilling depths of 7*, 9, 11, and 13 mm are lasermarked.

Insertable depth stops limit the drilling depths to the selected depths of 9, 11, or 13 mm.



Depth stop SCREW-LINE



NOTE

The depth stops SCREW-LINE are only compatible with the SCREW-LINE pilot and pre-drill .

* The lowest marking corresponds to a drilling depth of 7 mm and is of no significance for the CAMLOG® SCREW-LINE implants.

PARALLELING PINS SCREW-LINE WITH DEPTH MARKINGS

After each pilot and pre-drilling, the depth and axial directions are checked using the paralleling pins with depth markings.

The depth marks and diameter graduations on the paralleling pins allow inspection of the drilling depth and axis at each stage of pilot and pre-drilling.

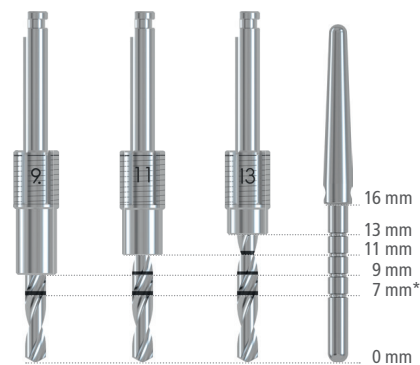

PUNCH-MARKING THE CORTICAL BONE

The round bur $\varnothing 2.3$ mm is used for punch-marking the cortical bone, which simplifies the use of the drills to follow. The bur is inserted up to the bur equator.

Recommended drilling speed: 800 rpm

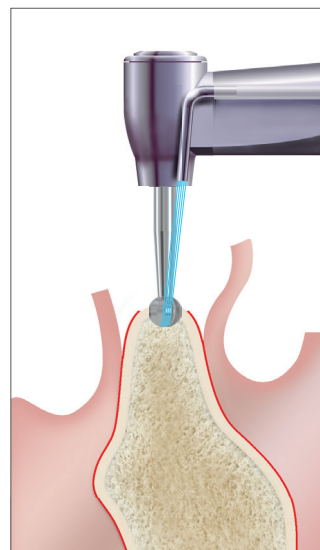

Punch-marking the cortical bone

* The lowest marking corresponds to a drilling depth of 7 mm and is of no significance for the CAMLOG® SCREW-LINE implants.

SURGICAL PROCEDURE

PILOT DRILLING AND DEPTH CONTROL

The pilot drill determines the depth and axis of the implant site. The depth marks on the drill correspond to the implant lengths 7*, 9, 11 and 13 mm. The maximum drilling depth is 16 mm. For safety reasons, a depth stop matching the proposed implant length should be used.

Recommended drilling speed: 800 rpm

If no drilling template is used, the depth stops may be placed to the pilot drill after the markings have been drilled.

Once drilling is complete, the depth and axis of the implant bed is checked using the paralleling pins. If several implants are being placed, a paralleling pin is inserted into the first hole in order to align the other implant axes.

The pilot drill is aligned parallel to the paralleling pin and visually checked from two planes (sagittal and transversal).



Pilot drill, Ø 2.0 mm
800 rpm

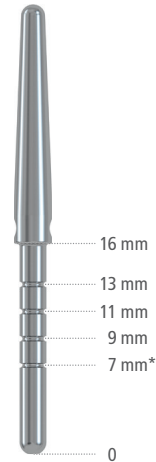

Paralleling pin
SCREW-LINE

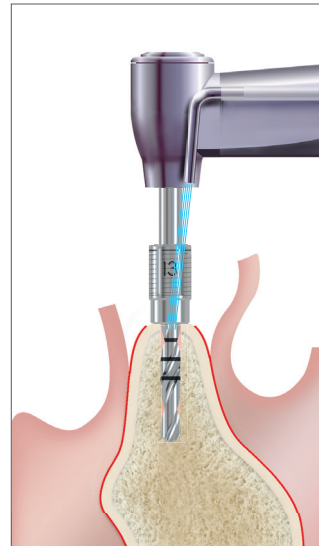

Pilot drilling

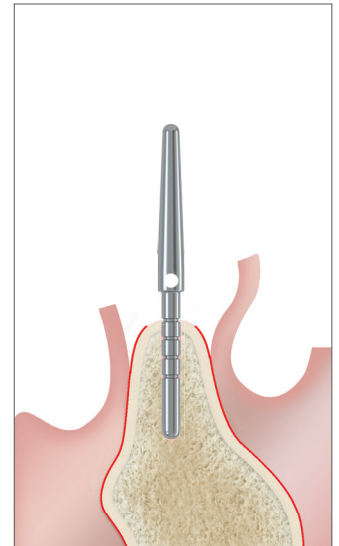

Depth control following pilot drilling

* The lowest marking corresponds to a drilling depth of 7 mm and is of no significance for the CAMLOG® SCREW-LINE implants.

PRE-DRILLING AND CONTROL AXIS ALIGNMENT

A tapered pre-drill SCREW-LINE with a coronal diameter of 2.8 mm and apical diameter of 1.7 mm is available for the SCREW-LINE configuration.

Recommended drilling speed: 600 rpm

The depth marks on the drill match the implant lengths 7*, 9, 11 and 13 mm. The maximum drilling depth is 16 mm. For safety reasons, a depth stop matching the proposed implant length should be used. Further drilling is performed with the form drills.

The axis alignment is controlled with the paralleling pin.

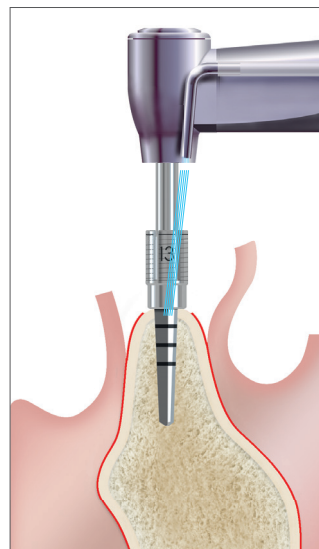
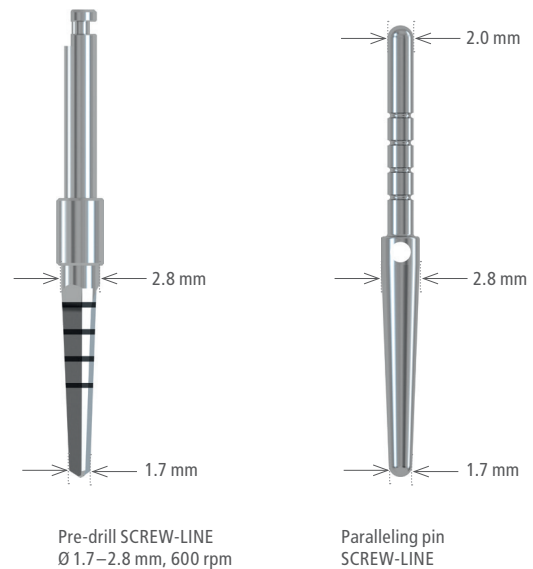

Pre-drilling

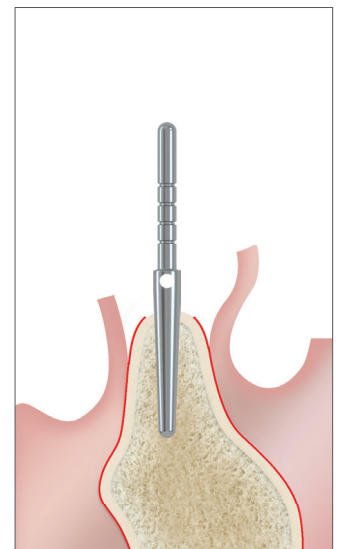

Control of axis alignment

* The lowest marking corresponds to a drilling depth of 7 mm and is of no significance for the CAMLOG® SCREW-LINE implants.

SURGICAL PROCEDURE

FORM DRILLING

Diameter- and length-specific form drills are available for each implant size. The form drills are color-coded and laser-marked.

The form drills included in the surgery sets are supplied with a color-coded, removable depth stop. This must only be used with form drills SCREW-LINE.

Depending on the specified drilling depth (implant length), the hole diameter is expanded progressively with the series of form drills until the intended implant diameter is achieved. The small graduations in diameter achieve a gentle preparation of the bone.

Recommended drilling speeds:

- Ø 3.3 mm 550 U/min
- Ø 3.8 mm 500 U/min
- Ø 4.3 mm 400 U/min
- Ø 5.0 mm 350 U/min
- Ø 6.0 mm 300 U/min

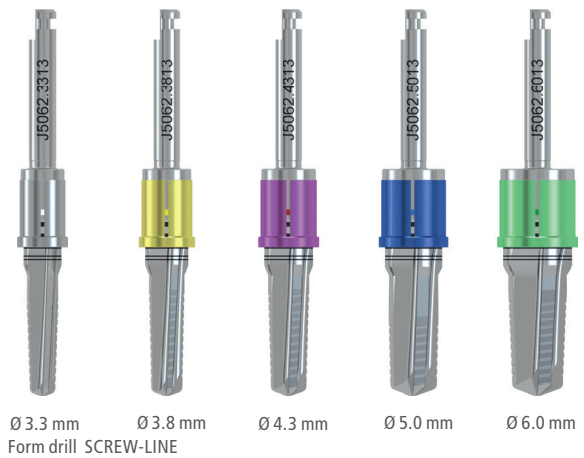
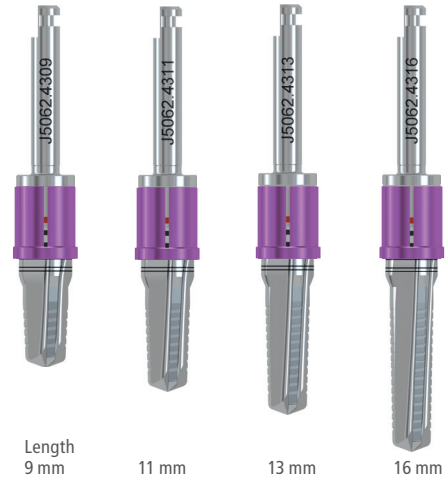

Form drill SCREW-LINE

Drill sequence in ascending order to the drill hole expansion up to the defined implant diameter.

FORMDRILLING FOR CAMLOG® SCREW-LINE Promote® plus

The CAMLOG® SCREW-LINE Promote® plus implants are machined over 0.4 mm in the neck section and can accordingly be placed 0.4 mm supracrestally*. If form drilling is performed with a depth stop, the CAMLOG® SCREW-LINE Promote® plus implant shoulder lies 0.4 mm supracrestal for a planar bone ridge.

The reusable depth stops can be used with replacement form drills (delivered without depth stops).

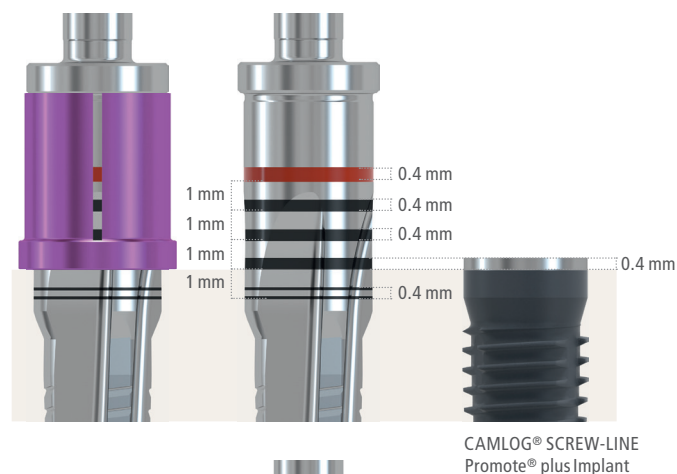

FORMDRILLING FOR CAMLOG® SCREW-LINE Promote®

A) Placement of the CAMLOG® SCREW-LINE Promote® Implant:

The CAMLOG® SCREW-LINE Promote® Implants are provided with a 1.4 mm high machined implant neck and can accordingly be placed 1.4 mm supracrestally*. In order to place the CAMLOG® Promote® Implant 1.4 mm supracrestally - on a planar bone ridge - form drilling is performed to the lower edge of the double line mark.

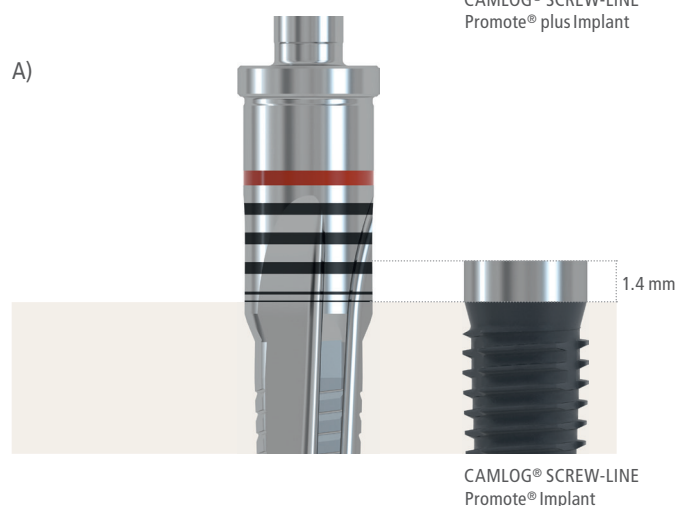

B) Individual form drilling:

If a different insertion depth is required, form drilling can be continued deeper in steps of 1 mm (watch for anatomic structures!). In this case, preparation is performed using the laser marks (black). The marks are arranged at intervals of 1.0 mm and are 0.4 mm in width.

CAUTION

The maximum apical overlength of the drills is 0.4 mm.

The depth stops must be removed before cleaning the drills. The cleaned depth stops must be reattached before sterilization (see "Preparation instructions for the CAMLOG®/CONELOG® Implant System", Art. No. J8000.0032). The depth stops can be reordered individually.

* Schwarz F, Alcoforado G, Nelson K, Schaer A, Taylor T, Beuer F, Strietzel FP. Impact of implant-abutment connection, positioning of the machined collar/microgap, and platform switching on crestal bone level changes. Camlog Foundation Consensus Report. Clin.Oral Impl. Res. 2014;25(11):1301-1303

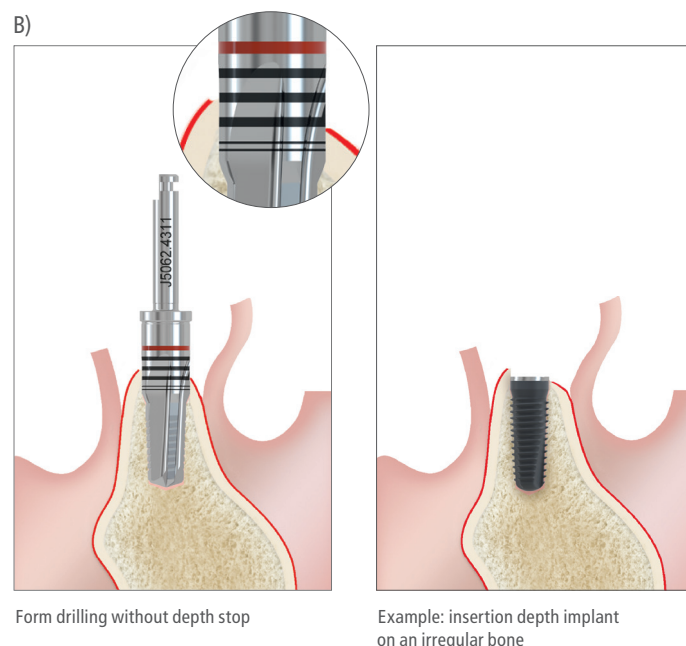

SURGICAL PROCEDURE

CHECKING THE IMPLANT BED

Probing the implant bed hole for fenestration is recommended. Results of probing tests for the absence of soft tissue in the implant bed hole must be documented in the patient file.

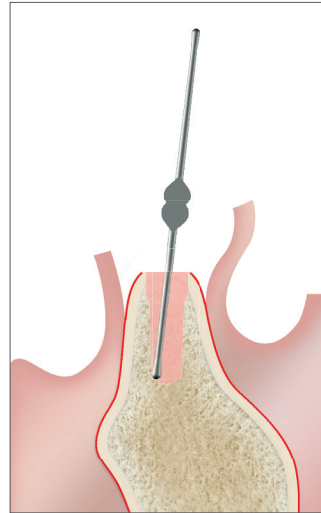

Checking the implant bed

CORTICAL BONE DRILLING

If the bone quality is class 1* the cortical bone drill enables reduced-torque implant insertion through controlled circular expansion of the implant bed. The flattened drill tip serves as the depth stop. A color-coded laser-marked cortical bone drill is available for each implant diameter.

Recommended drilling speed in rpm:

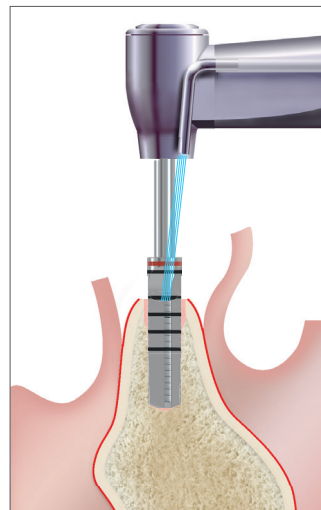
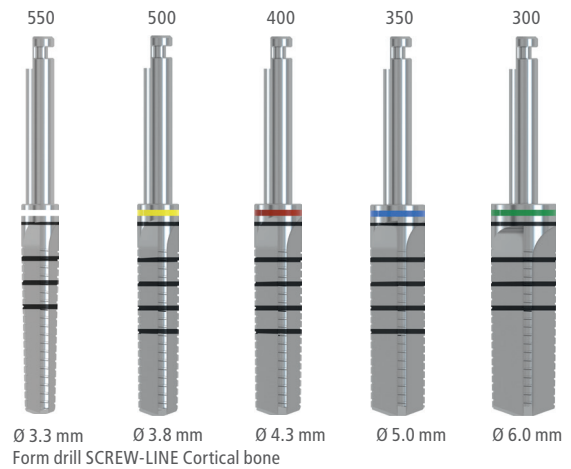

Cortical bone drilling Ø 4.3 mm for implant length 13 mm

* Bone quality as documented in Lekholm U, Zarb GA. Patient selection and preparation. In: Branemark PI, Zarb GA, Albrektsson T, editors. Tissue-integrated prostheses-Osseointegration in Clinical Dentistry. Chicago: Quintessence Publishing Co; 1985. p. 199–209

TAPPING

All CAMLOG® SCREW-LINE implants come with a self-tapping thread. Use of a tap is recommended for bone quality categories 1* and 2*.

The maximum speed must not exceed 15 rpm when performing power-assisted tapping. We recommend manual tapping.

* Bone quality as documented in Lekholm U, Zarb GA. Patient selection and preparation. In: Branemark PI, Zarb GA, Albrektsson T, editors. Tissue-integrated prostheses-Osseointegration in Clinical Dentistry. Chicago: Quintessence Publishing Co; 1985. p. 199–209

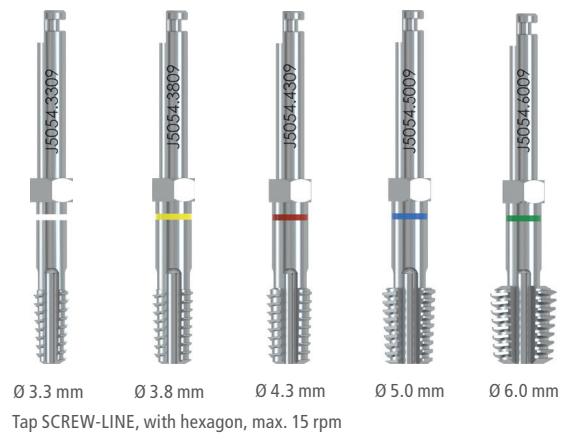

Manual tapping is performed with tap adapters for the tap SCREW-LINE and the locked torque wrench. Make sure to pay attention to the axial direction of the implant bed when inserting and removing the tap. The limit for insertion of the tap is the upper edge of the cutting blade.

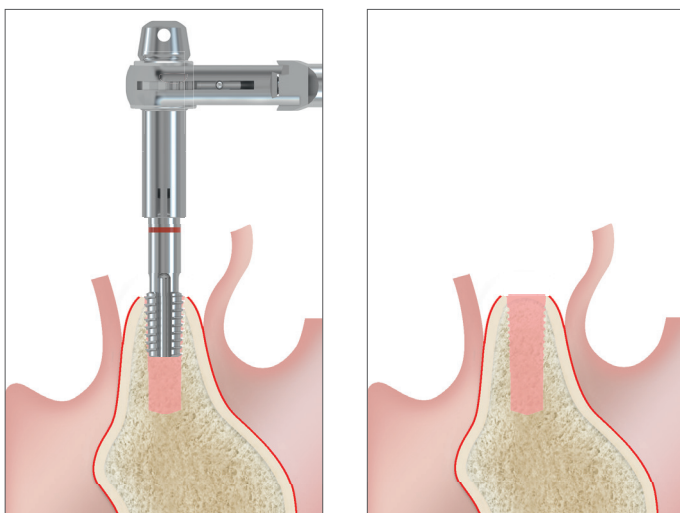
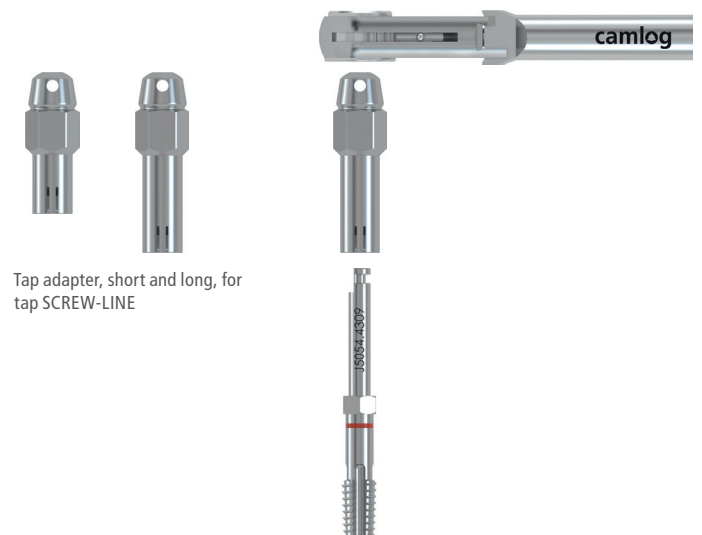

Tapping in the upper region of the implant bed

SURGICAL PROCEDURE

IMPLANTATION

GENERAL INFORMATION ON PACKAGING AND IMPLANT HANDLING

A) Exterior packaging (cardboard) with label:

The label on the exterior packaging contains relevant system information and is applied on three sides. This means that the label is clearly readable regardless of stacking of the packages.



Example product label on the exterior packaging:

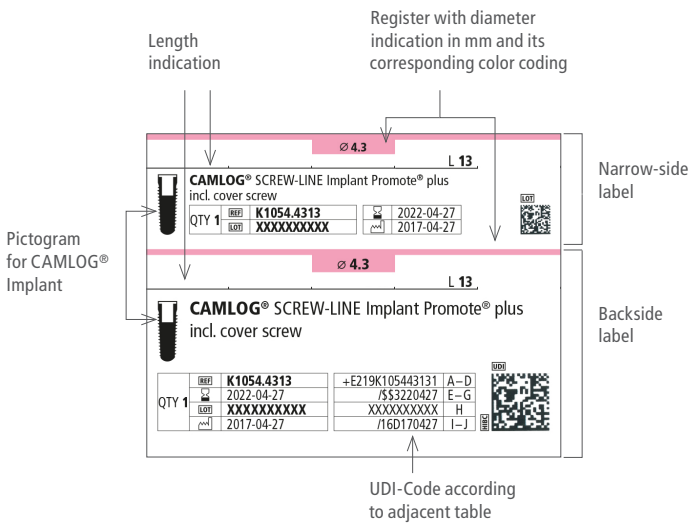

UDI CODE

A B C DE F G H I J K
+E219K105443131 / \$\$\$3220427XXXXXXXXXX / 16D170427+

Sections of the primary code (UDI-DI)	Code	Explanation
A	+	Protected HIBC-ID (1 digit)
B	E219	Manufacturer's code (Altatec)
C	K10544313	Article number (max. 13 digits)
D	1	Quantity index (number of packaging units, 1 digit)
Sections of the secondary code (UDI-DI)	Code	Explanation
E	/	Separator primary/secondary
F	\$\$3	Identifier for expiry date
G	220427	Expiry date (6 digits) 27.04.2022
H	XXXXXXXXXX	Manufacturer's batch (10 digits)
I	/16D	Identifier for date of manufacture
J	170427	Date of manufacture (6 digits) 27.04.2017
K	+	Variable test mark

Further information on the exterior packaging:

The bottom side of the CAMLOG® Implant packaging refers to the instruction manual in electronic form: <https://ifu.camlog.com>

In addition, it includes a QR code which links directly to the corresponding webpage.



The left side view of the CAMLOG® Implant packaging contains the CE label, the corresponding ISO warnings as well as the address of the legal manufacturer.

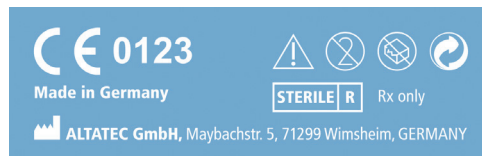

B) Transparent blister with Tyvek® foil and primary label:

The blister with the Tyvek® foil represents the primary packaging, the contents of which are sterile - implant holder with implant and cover screw. Furthermore, the blister includes four self-adhesive patient labels. These can, for example, be used for the patient records, the implant pass, the letter of referral etc.

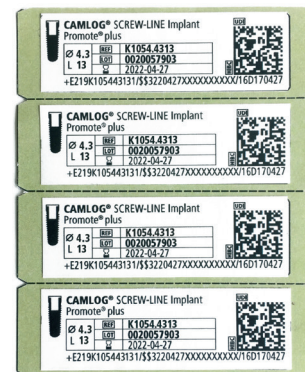

C) Implant holder with implant and cover screw:

The implant retention system securely fixates the implant and the cover screw in the packaging. Both the implant and the cover screw can be released and removed via a simple click mechanism with the implant holder. In addition, the implant can be clearly identified in the implant holder after removal from the primary packaging:

- One side of the implant holder contains information which identifies the type of implant.
- The implant diameter can be identified via the color-coding of the insertion post and the cover screw.
- A scale on the bottom side of the implant holder allows reading the length of the implant: the position of the titanium retaining plate on the scale gives the implant length 9, 11, 13 and 16 mm.

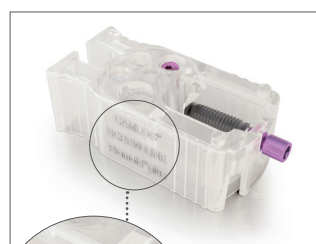

Information on the type of implant

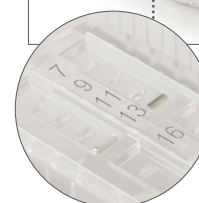

Scale to determine the length of the implant

D) Mounted insertion posts:

The implants are secured in the implant holder with a color-coded insertion post corresponding to the diameter. The insertion posts are **mounted** in the implant and can be pulled off easily from the implant after implantation without requiring further tools.



SURGICAL PROCEDURE

E) Insertion tools:

The implant can be picked up directly with the insertion tool via the mounted insertion post and removed from the implant holder. One of the five illustrated insertion tools can be used for this purpose.

The insertion posts and insertion tools are designed such, that they are also suitable for narrow gaps: none of the components required for inserting the implant have a diameter greater than that of the implant itself.

Furthermore, the long insertion tools also allow the placement of implants in narrow and deep anatomical situations.

The three manual insertion tools for use with the wrench (long, short, extra short).



The two insertion tools with ISO shaft (short and long) for use with the angled hand piece.

The figure illustrates the use of a handpiece insertion tool (with ISO shaft) with insertion post for the CAMLOG® Implant Ø 3.3 mm under tight interdental conditions.

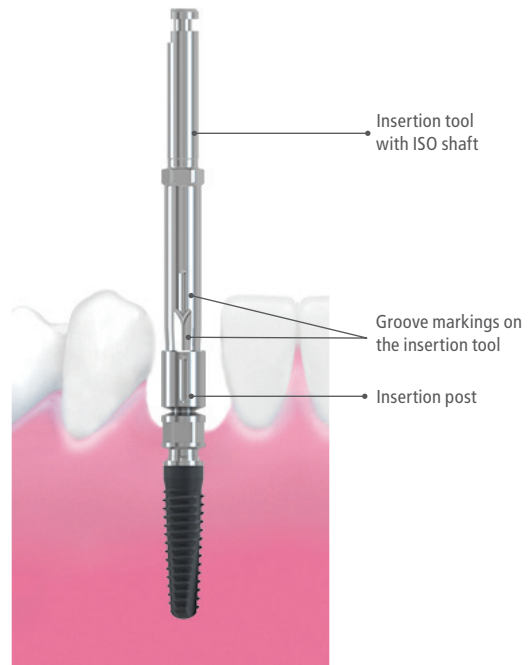

OPENING OF THE PACKAGING AND TRANSFER OF THE IMPLANT HOLDER TO THE STERILE ZONE

The exterior packaging is opened with the perforated packaging tab.

NOTE

If the perforated packaging tab is partially or fully open, the packaging is deemed damaged and the implant may no longer be used.



The four self-adhesive patient labels included with the blister, are intended for documentation purposes for example:

- Implant pass
- Letter of referral
- Patient records

The blister with the Tyvek® foil forms the sterile barrier. As long as the blister as well as the Tyvek® foil are undamaged, sterility of the content is assured.



Opening of the blister:

At the two sharp angle corners, the blister is fitted with tabs which allow easy separation of the Tyvek® foil from the blister.



SURGICAL PROCEDURE

There are two ways to transfer the implant holder to the sterile zone (**A and B**):

A: DISCARDING THE IMPLANT HOLDER ONTO THE STERILE SHELF

The opened blister is gently compressed between two fingers in the marked position.

The blister is designed such, that the implant holder is retained in the blister as long as finger pressure is maintained. This allows controlled placement over the sterile shelf.

By releasing finger pressure, the holder can be discarded onto the sterile shelf in a controlled manner.

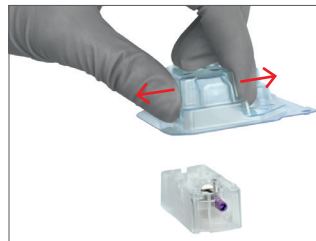
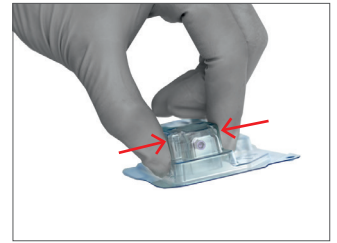
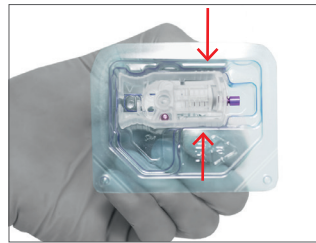

B: PASSING THE IMPLANT HOLDER TO THE IMPLANTOLOGIST

The opened blister is passed to the implantologist.

The implantologist takes the implant holder with two fingers at the intended place.

Then the implant holder can be used in the sterile zone.

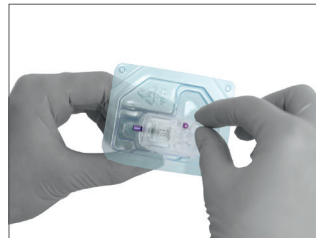

PICKING UP THE INSERTION POST WITH THE MANUAL INSERTION TOOL

The front part of the implant holder is held between two fingers and the insertion tool is mounted into the insertion post **by applying pressure**. This ensures a secure seat of the insertion tool in the insertion post.

Contamination from non-sterile instruments must be avoided.

NOTE

It should be noted that **picking up the insertion post with the insertion tool is done by applying slight pressure**. This ensures secure retention of the insertion post in the insertion tool.

The three groove markings on the head of the insertion post serve easy picking up of the post with the insertion tool, which is also fitted with the corresponding three markings.

Furthermore, the three groove markings on the insertion tool and on the insertion post relate to the groove position of the implant-abutment connection.

The further steps for removing the implant are as follows:

- Hold the implant holder at the rear section (see arrows in illustration) and press together to release the lock on the implant holder and thus release the implant;
- Loosen the insertion post with a slight twist (approx. 30° clockwise with the insertion tool);
- Lift out insertion post in **upward direction** (do not tilt).

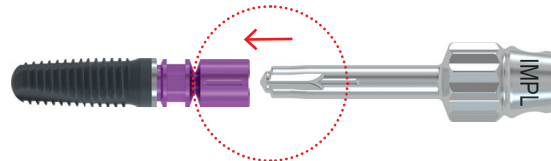
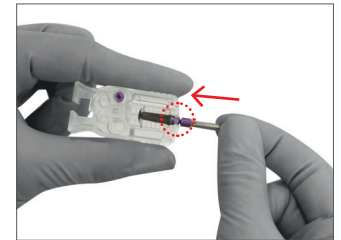
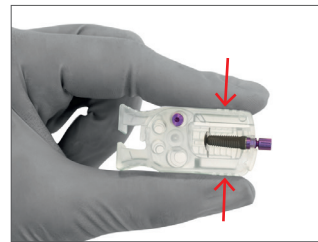

Observe the correct alignment during the pick-up process!

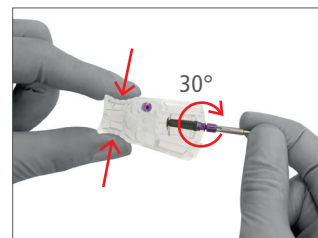
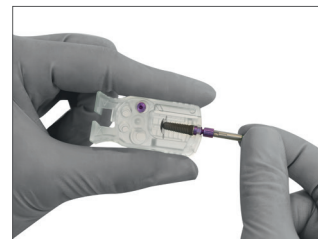

SURGICAL PROCEDURE

PICKING UP THE INSERTION POST WITH THE ANGLED HAND PIECE

Optionally, the insertion post can also be picked up directly with the ISO shaft handpiece insertion tool on an angled hand piece. The front part of the implant holder is held and then the insertion post is picked up with the handpiece insertion tool **by applying pressure**.

During the pick-up process, observe the correct alignment of the 3 groove markings on the head of the insertion post and the insertion tool.

Contamination from non-sterile instruments must be avoided.

NOTE

It should be noted that **picking up the insertion post with the insertion tool is done by applying slight pressure**. This ensures secure retention of the insertion post in the insertion tool.

The further steps for removing the implant are as follows:

- Hold the implant holder at the rear section (see arrows in illustration) and press together to release the lock on the implant holder and thus release the implant;
- Remove the insertion post from the holder with a slight twist (approx. 30° clockwise with the insertion tool);
- Lift out the insertion post by pulling the angled hand piece upwards (do not tilt).

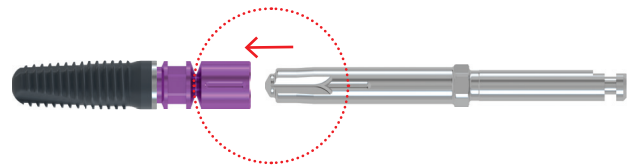
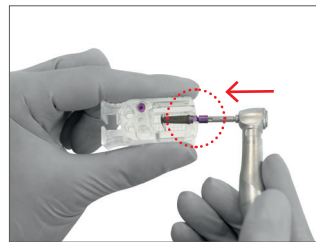

Observe the correct alignment during the pick-up process!

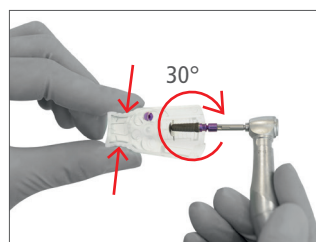

IMPLANT INSERTION AND POSITIONING

Using the insertion tool, the implant is inserted into the implant bed and carefully screwed in clockwise either manually or with the angled hand piece (maximum speed may not exceed 15 rpm). Pay attention to the axial alignment of the implant bed.

In the case of manual insertion, once the implant has been inserted into the implant bed, the implant can be screwed into its final position with the wrench.

If the thread was tapped in advance, the positions of the threaded ends in the cortical bone and on the implant must match.

It is recommended to first rotate the insertion tool with the implant carefully to the left manually, until the thread socket can be felt. Then the implant is screwed in clockwise manually with the insertion tool.

When reaching the planned insertion depth (see section on form drilling), one of the 3 grooves should face in a vestibular direction.

If it was decided to set preparation depths for the implants individually by removing the depth stop during form drilling, this must be kept in mind when inserting the implant. It is possible to individually position implants vertically to match the drilling depth.

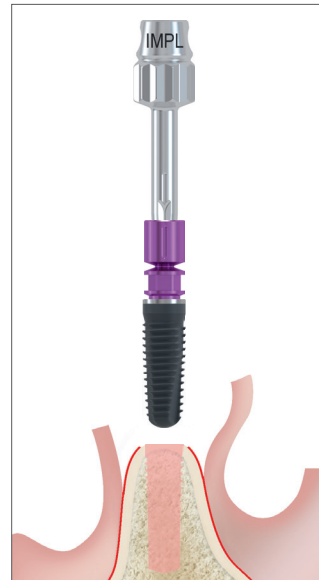

Insertion of implant with a manual insertion tool

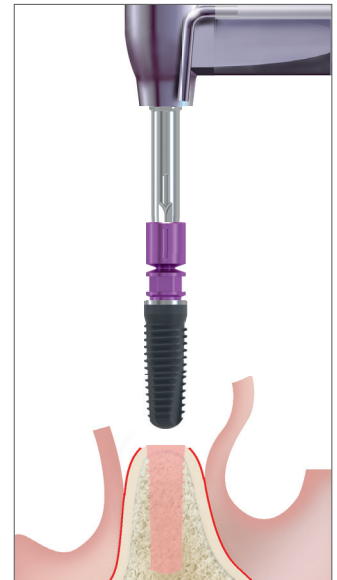

Insertion of implant with a machine insertion tool

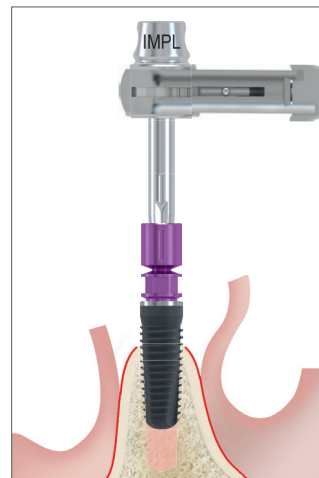

Screw insertion of implant with manual insertion tool and wrench (max. 15 rpm)

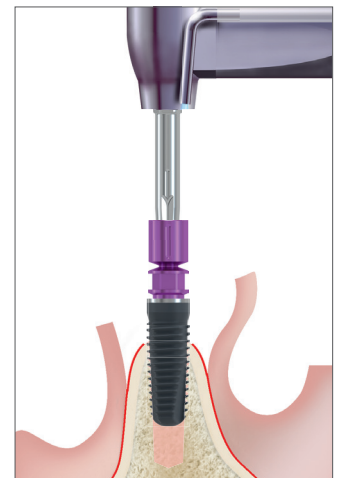

Screw insertion of implant with a machine insertion tool and angled hand piece (max. 15 rpm)

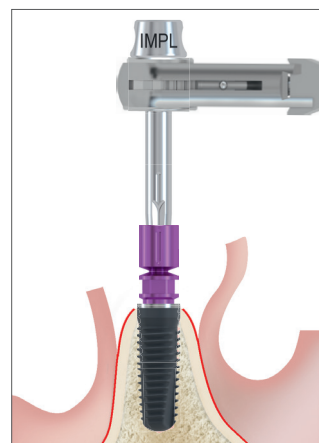

Manually screwed in implant

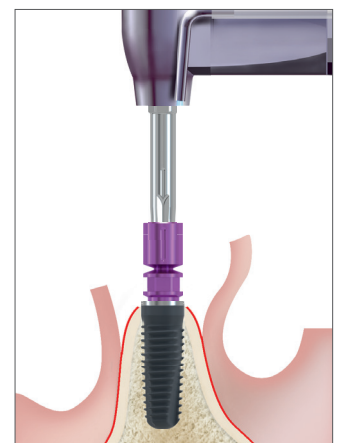

Machine screwed in implant

SURGICAL PROCEDURE

The following is to be observed during implantation:

Groove markings are applied to the insertion tool and the insertion post which correspond to the three grooves of the implant-abutment connection. These permit a check of the groove positions during the insertion and their orientation as required for the prosthesis.

If the dental technician has not indicated the groove position, a vestibular orientation is advantageous in most cases since the angle of angulated abutments originates at a groove.

NOTE

Keep in mind during positioning of the grooves that turning to the next groove position (120°) will cause the screw implant to be inserted about 0.2 mm deeper.

Manual insertion tool for wrench

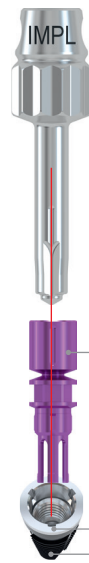

Machine insertion tool with ISO shaft

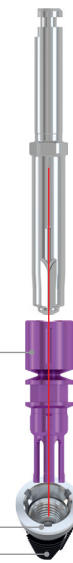

Removal of the insertion post for manual screwing in

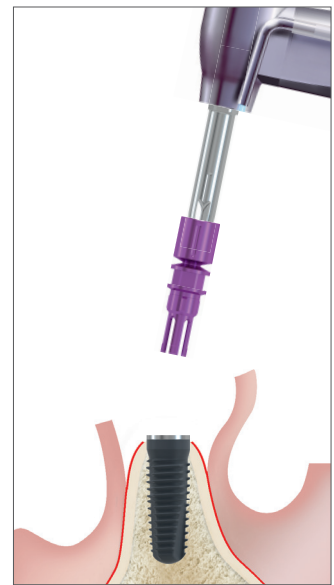

Removal of the insertion post for machine screwing in

After successful checking of the implantation depth (see section "Form drilling") as well as the position of the grooves (see above), the insertion post can be pulled from the implant using the torque wrench or with the angled hand piece. Attention should be paid to sufficient primary stability of the implant. Prior to removal, ensure sufficient mating between the insertion tool and the insertion post **with slight axial pressure** on the insertion tool.

If the primary stability is low after placing the implant, the implant can be stabilized downwards with a probe or forceps during extraction of the insertion post.

ADDITIONAL INSTRUMENTS

PRE-DEFINED BREAKING POINT OF THE INSERTION POST

To protect the inner configuration of the implant, the insertion posts are fitted with a pre-defined breaking point. If the torque is too high during insertion of the implant, the insertion post snaps off at the pre-defined breaking point. This ensures that the inner configuration of the implant is not damaged and that the fracture fragment of the post can be removed with forceps as a single piece from the implant.

The fractured piece must be secured with a ligature prior to removal to avoid aspiration.

If the snapping at the predetermined breaking point occurs at the same time as final positioning of the implant, the fragment of the insertion post is extracted as described above, and the procedure can be continued as planned. The cover screw or a healing cap is applied to the implant or it is already fitted with a prosthetic component.

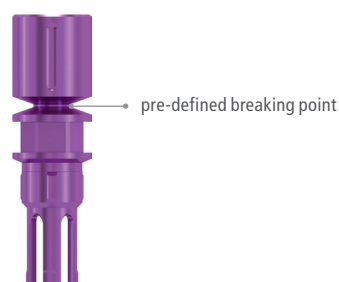

REMOVAL ADAPTER FOR IMPLANTS

If the implant is not in the final position when the insertion post snaps at the pre-defined breaking point, the implant must be removed as described in the following, and the reason for snapping investigated.

In order to remove the implant after snapping of the insertion post at the pre-defined breaking point, CAMLOG® Removal adapters are available for all CAMLOG® SCREW-LINE implants.

In order to remove the implant, the manual insertion tool is mounted to the removal adapter. Here it should be noted that picking up the removal adapter with the insertion tool is done by applying slight pressure.

Three lateral markings correspond with the cams of the removal adapter and thus allow easy insertion of the removal adapter into the implant, until the cams fit the grooves.



CAMLOG® Removal adapters for all diameters

NOTE

The CAMLOG® Removal adapter should only be used for the explanation not osseointegrated implants.

The CAMLOG® Removal adapter should not be used to change implant axis or to adjust the height of the implant.

Otherwise the inner configuration of the implant can be damaged.

SURGICAL PROCEDURE

Afterwards the implant can be unscrewed with the mounted removal adapter using the insertion tool and the locked torque wrench or the angled hand piece. The implant must be disposed.



Insertion of the removal adapter to the implant

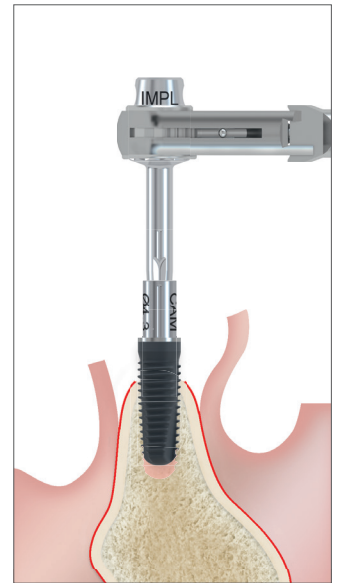

Unscrewing the implant using the removal adapter, the insertion tool as well as the locked torque wrench

SUBMERGED HEALING

The cover screw for submerged healing is located in the middle section of the implant holder and protected against falling out (red circle) in a provided well (Ø 3.3 mm, Ø 3.8 mm, Ø 4.3 mm, Ø 5.0 mm and Ø 6.0 mm).

By closing (compressing) the implant holder (see illustration) the cover screw can be released. The screw is freely accessible after this procedure. This procedure is only possible if the insertion post and implant are no longer in place.

Using a screwdriver, the cover screw can be picked up directly from the implant holder **by applying slight pressure**.

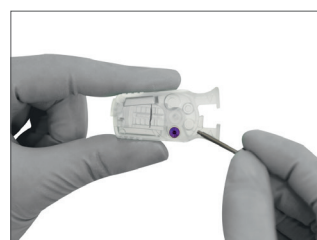
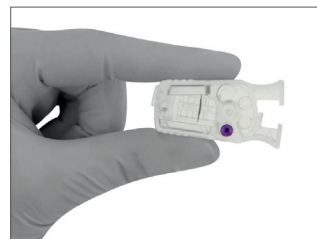
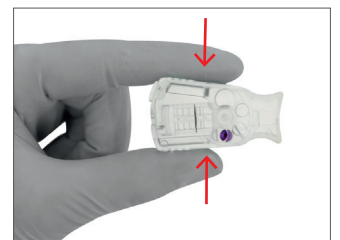
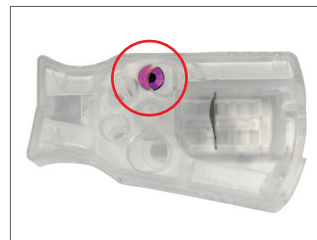

Pick up the cover screw with the screwdriver, hex, and insert it into the CAMLOG® SCREW-LINE implant manually controlled (danger of aspiration!). The cover screw must only be tightened manually controlled using the hex screwdriver.

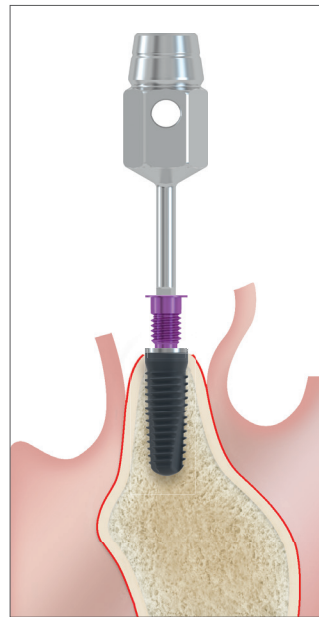

Inserting the CAMLOG® Cover screw

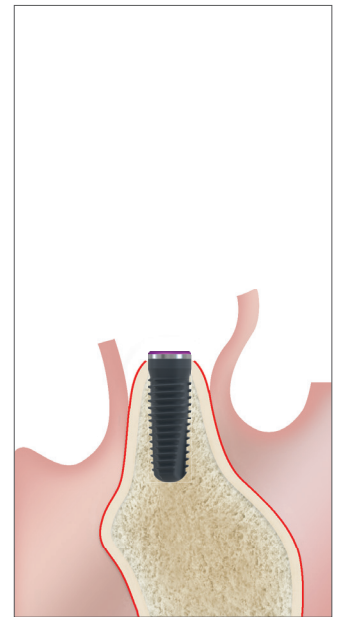

CAMLOG® SCREW-LINE implant with CAMLOG® Cover screw

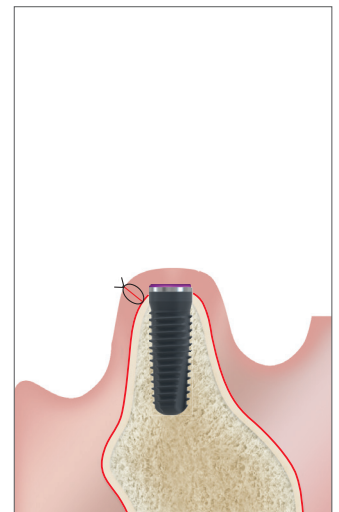

Wound closure

SURGICAL PROCEDURE

TRANSGINGIVAL HEALING

CAMLOG® HEALING CAPS

Use of the CAMLOG® Healing caps supports the development of the periimplant soft tissue. CAMLOG® Healing caps are available in three different geometries:

- cylindric
- wide body
- bottleneck

The healing caps are color-coded to match the respective implant diameter.

CAMLOG® Healing caps are inserted into the CAMLOG® SCREW-LINE implant and tightened manually using a screwdriver, hex. The healing cap rests on the machined implant shoulder and does fully cover it.

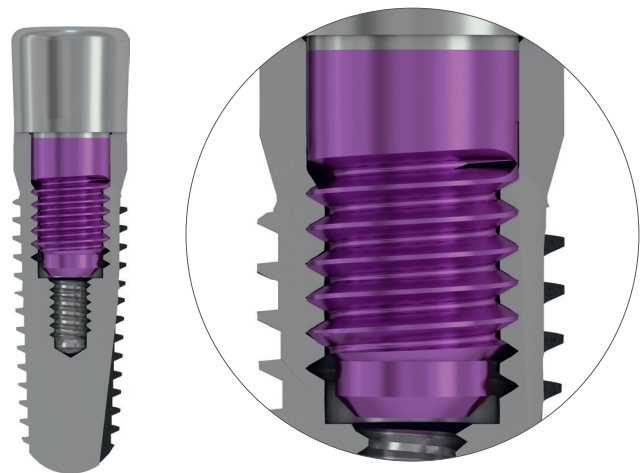

Connection CAMLOG® SCREW-LINE implant – CAMLOG® Healing cap

CAMLOG® HEALING CAPS PS FOR PLATFORM SWITCHING



The CAMLOG® Healing caps PS (cylindrical, wide body, bottleneck) are tapered in diameter on the apical end and enable the adaptation of soft tissue over the implant shoulder.

IMPORTANT NOTE!

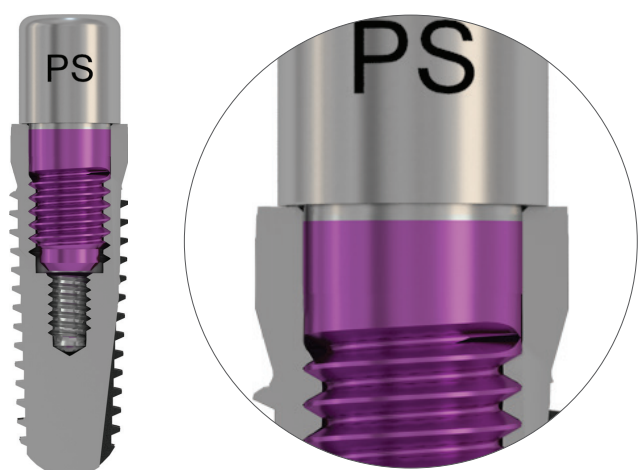
If CAMLOG® Healing caps PS are used for healing, the later prosthetic restoration, including the CAMLOG® Impression taking, must use CAMLOG® Prosthetic components PS for platform switching to prevent tissue injury!

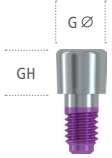

Connection CAMLOG® SCREW-LINE implant – CAMLOG® Healing cap PS

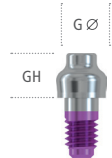
	Article	Art.-No.	Ø	GH	G Ø
	CAMLOG® Healing cap, cylindrical	J2015.3320	3.3 mm	2.0 mm	3.3 mm
		J2015.3340		4.0 mm	3.3 mm
		J2015.3820	3.8 mm	2.0 mm	3.8 mm
		J2015.3840		4.0 mm	3.8 mm
		J2015.3860*		6.0 mm	3.8 mm
		J2015.4320	4.3 mm	2.0 mm	4.3 mm
		J2015.4340		4.0 mm	4.3 mm
		J2015.4360*		6.0 mm	4.3 mm
		J2015.5020	5.0 mm	2.0 mm	5.0 mm
		J2015.5040		4.0 mm	5.0 mm
		J2015.5060*		6.0 mm	5.0 mm
		J2015.6020	6.0 mm	2.0 mm	6.0 mm
		J2015.6040		4.0 mm	6.0 mm
		J2015.6060*		6.0 mm	6.0 mm
J2015.6060*	6.0 mm	6.0 mm			
	CAMLOG® Healing cap, wide body	J2014.3320	3.3 mm	2.0 mm	4.5 mm
		J2014.3340		4.0 mm	4.5 mm
		J2014.3820	3.8 mm	2.0 mm	4.9 mm
		J2014.3840		4.0 mm	5.0 mm
		J2014.3860		6.0 mm	5.0 mm
		J2014.4320	4.3 mm	2.0 mm	5.4 mm
		J2014.4340		4.0 mm	5.5 mm
		J2014.4360		6.0 mm	5.5 mm
		J2014.5020	5.0 mm	2.0 mm	6.1 mm
		J2014.5040		4.0 mm	6.2 mm
		J2014.5060		6.0 mm	6.2 mm
		J2014.6020	6.0 mm	2.0 mm	7.1 mm
		J2014.6040		4.0 mm	7.2 mm
		J2014.6060		6.0 mm	7.2 mm
J2014.6060	6.0 mm	7.2 mm			
	CAMLOG® Healing cap, bottleneck	J2011.3340	3.3 mm	4.0 mm	3.5 mm
		J2011.3840	3.8 mm	4.0 mm	4.0 mm
		J2011.3860		6.0 mm	4.0 mm
		J2011.4340	4.3 mm	4.0 mm	4.5 mm
		J2011.4360		6.0 mm	4.5 mm
		J2011.5040	5.0 mm	4.0 mm	5.2 mm
		J2011.5060		6.0 mm	5.2 mm
		J2011.6040	6.0 mm	4.0 mm	6.2 mm
		J2011.6060		6.0 mm	6.2 mm

GH: Gingival height

GØ: Gingival diameter

* suitable for bite registration

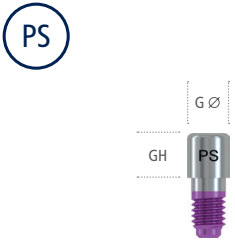
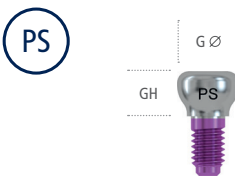
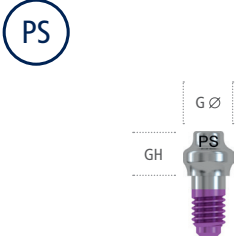
	Article	Art.-No.	Ø	GH	G Ø
	CAMLOG® Healing cap PS, cylindrical	K2005.3820	3.8 mm	2.0 mm	3.3 mm
		K2005.3840		4.0 mm	3.3 mm
		K2005.3860*		6.0 mm	3.3 mm
		K2005.4320	4.3 mm	2.0 mm	3.8 mm
		K2005.4340		4.0 mm	3.8 mm
		K2005.4360*		6.0 mm	3.8 mm
		K2005.5020	5.0 mm	2.0 mm	4.4 mm
		K2005.5040		4.0 mm	4.4 mm
		K2005.5060*		6.0 mm	4.4 mm
		K2005.6020	6.0 mm	2.0 mm	5.1 mm
		K2005.6040		4.0 mm	5.1 mm
		K2005.6060*		6.0 mm	5.1 mm
			CAMLOG® Healing cap PS, wide body	K2004.3840	3.8 mm
K2004.3860	6.0 mm			5.0 mm	
K2004.4340	4.3 mm			4.0 mm	5.5 mm
K2004.4360				6.0 mm	5.5 mm
K2004.5040	5.0 mm			4.0 mm	6.2 mm
K2004.5060				6.0 mm	6.2 mm
K2004.6040	6.0 mm			4.0 mm	7.2 mm
K2004.6060				6.0 mm	7.2 mm
	CAMLOG® Healing cap PS, bottleneck	K2001.3840	3.8 mm	4.0 mm	4.0 mm
		K2001.3860		6.0 mm	4.0 mm
		K2001.4340	4.3 mm	4.0 mm	4.5 mm
		K2001.4360		6.0 mm	4.5 mm
		K2001.5040	5.0 mm	4.0 mm	5.2 mm
		K2001.5060		6.0 mm	5.2 mm

GH: Gingival height
 GØ: Gingival diameter
 * suitable for bite registration

CAMLOG® HEALING CAPS, CYLINDRICAL, AND WIDE BODY

The cylindrical and wide body CAMLOG® Healing caps are for standard use. After removal of the CAMLOG® Cover screw, diameter-matching CAMLOG® Healing caps are screwed in manually with a screwdriver, hex. A gingival height ensuring that the healing cap sits 1–1.5 mm supragingivally should be selected. The CAMLOG® Impression is taken once the peri-implant soft tissue has been stabilized.

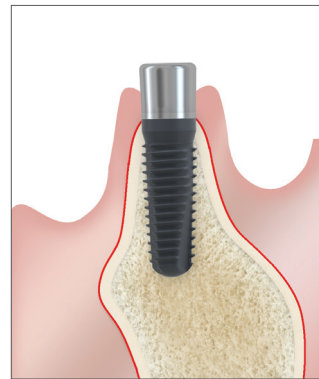

CAMLOG® Healing cap, cylindrical

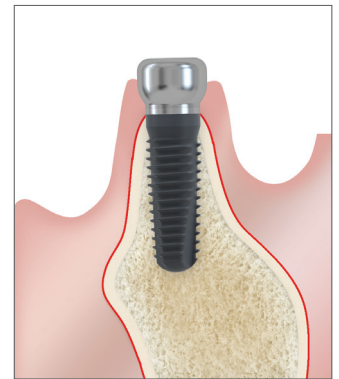

CAMLOG® Healing cap, wide body

CAMLOG® HEALING CAPS PS, CYLINDRICAL, AND WIDE BODY

CAMLOG® SCREW-LINE Implants with Promote® plus surface are suitable for the platform switching option. Because the surface is brought further upward, more bone is available close to the implant shoulder. Because the surface is brought further upward, more bone is available in coronal direction. The shift in the horizontal shoulder towards the implant axis at the implant shoulder level ensures more space for soft-tissue management.

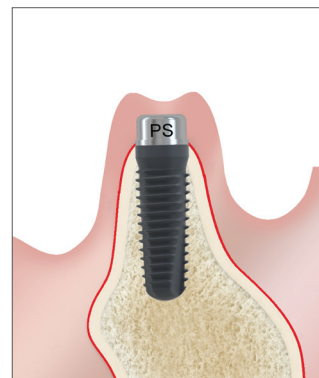

CAMLOG® Healing cap PS, cylindrical, Height 2.0 mm, for submerged healing



CAMLOG® Healing cap PS, cylindrical, Height 4.0 mm, for submerged healing

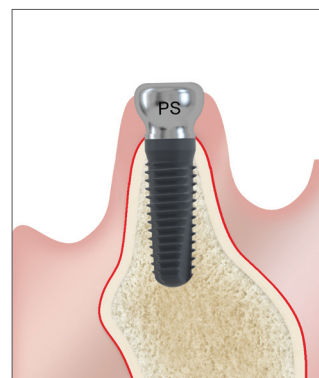

CAMLOG® Healing cap PS, wide body

SURGICAL PROCEDURE

CAMLOG® HEALING CAP BOTTLENECK

In esthetically challenging areas, the treatment outcome can be optimized by using CAMLOG® Healing caps, bottleneck. The coronally tapered cross-cut enables soft-tissue generation during healing.

After 3–4 weeks (and before the final organization of the elastic fibers) a CAMLOG® Healing cap cylindrical is screwed in. No tissue should be excised.

The tissue is coronally suppressed and thereby forms a papilla-like structure. The impression is taken once the peri-implant soft tissue has stabilized.

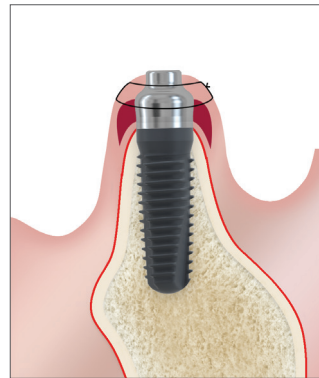

Healing stage



Soft-tissue generation

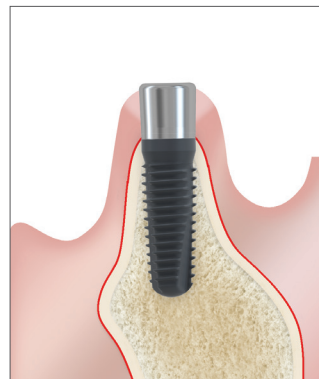

Coronal suppression of the soft tissue by substitution with a CAMLOG® Healing cap cylindrical

IMPORTANT NOTES

To prevent soft tissue injury, CAMLOG® Healing caps PS should only be replaced by CAMLOG® Healing caps PS!

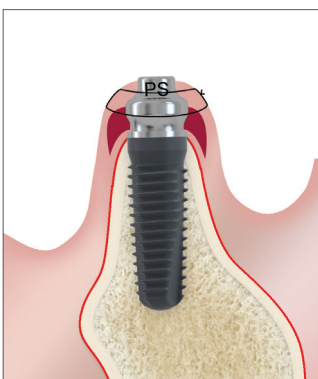

Healing phase with a CAMLOG® Healing cap PS, bottleneck

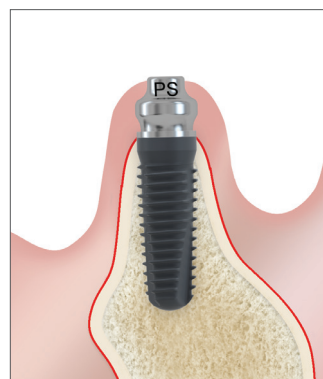

Soft-tissue generation with a CAMLOG® Healing cap PS, bottleneck

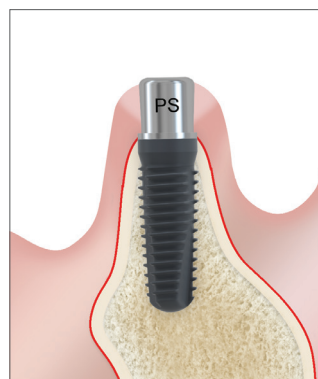

Coronal suppression of the soft tissue by substitution with a CAMLOG® Healing cap PS, cylindrical

TISSUE GENERATION/TISSUE SUPPROT

One-step use
(transgingival)

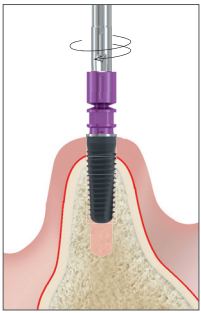

Two-step-use
(submerged)

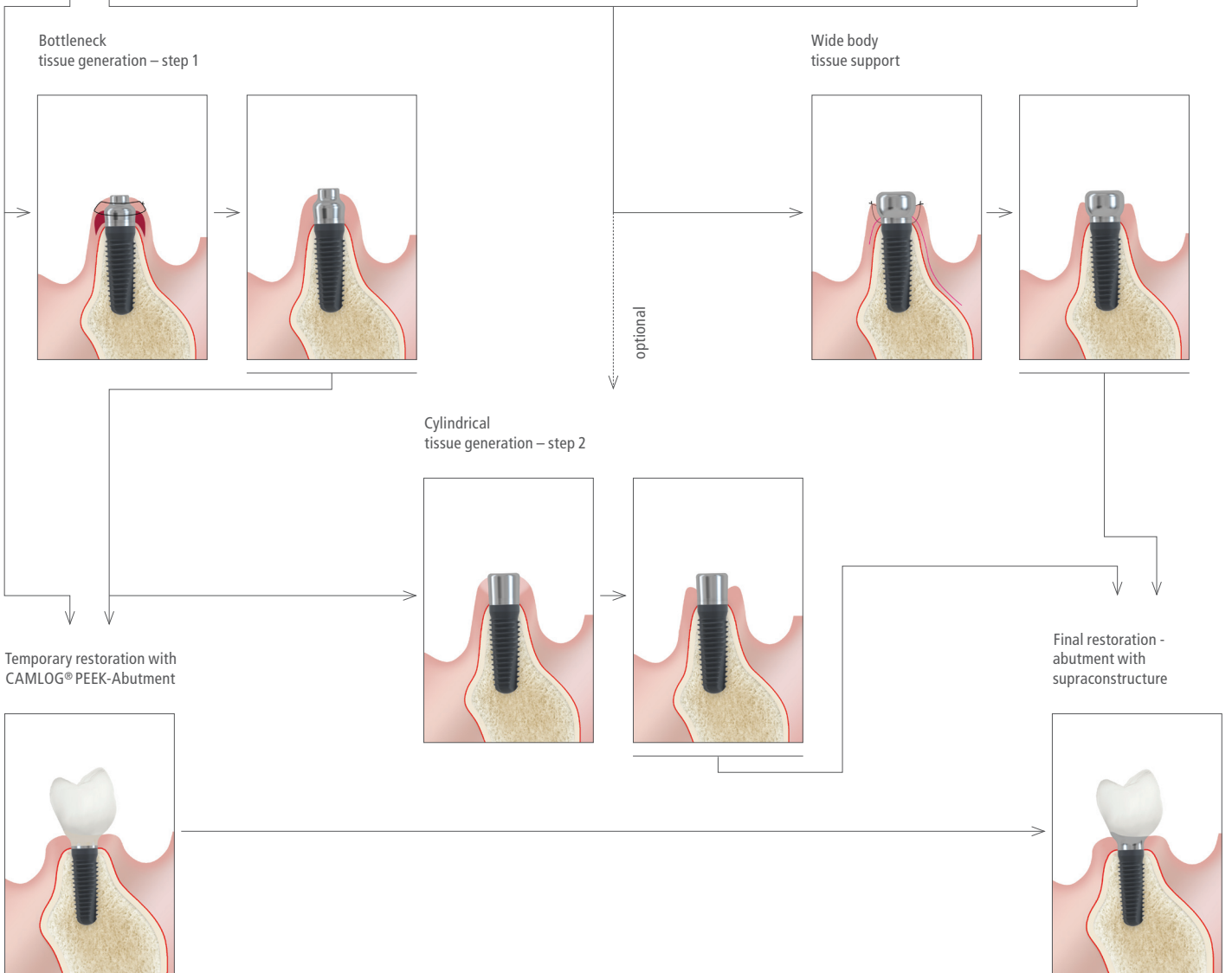
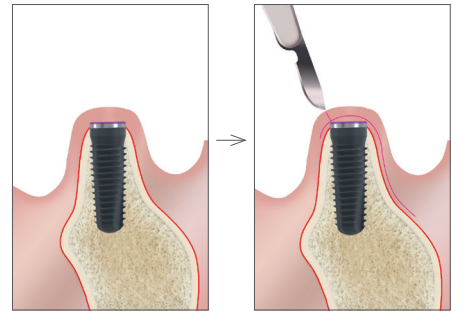

FURTHER DOCUMENTATION

Further information on the CAMLOG® Products can be found in the following documents:

- CAMLOG® Product catalog
- CAMLOG® Working instructions
- CAMLOG® Instruction manuals
- Preparation instructions
- CAMLOG Literature overview
- CAMLOG and science

The documents are available from the local CAMLOG representative.
See also:

<https://ifu.camlog.com>
www.camlog.com

TRADEMARKS AND COPYRIGHT

Protected brand names (trademarks) are not specially indicated. The absence of such indication does not mean that it is not a trademarked name. This publication with all its parts is protected by copyright. Any exploitation beyond the narrow limits of the copyright act is not permissible without the approval of CAMLOG Biotechnologies AG and is subject to legal sanctions.



HEADQUARTERS

CAMLOG Biotechnologies AG | Margarethenstr. 38 | 4053 Basel | Switzerland
Phone +41 61 565 41 00 | Fax +41 61 565 41 01 | info@camlog.com | www.camlog.com

Manufacturer of CAMLOG® and CONELOG® products: ALTATEC GmbH | Maybachstr. 5 | 71299 Wimsheim | Germany

